

**USE OF SOLANUM INCANUM FOR WATER TREATMENT AT HOUSEHOLD
LEVEL : A CASE OF NAKYIJEERA SPRING IN NAMILYANGO VILLAGE
KISENYI CELL**

PETER WANABADI

M22B32/034

**A DISSERTATION SUBMITTED TO THE FACULTY OF ENGINEERING, DESIGN AND
TECHNOLOGY IN PARTIAL FULFILLMENT OF THE REQUIREMENTS FOR THE AWARD
OF THE DEGREE OF BACHELOR OF CIVIL AND ENVIRONMENTAL ENGINEERING OF
UGANDA CHRISTIAN UNIVERSITY**

February, 2026



**UGANDA CHRISTIAN
UNIVERSITY**

A Centre of Excellence in the Heart of Africa

ACKNOWLEDGEMENT

Life is a combination of setbacks, exposures to success and experiences that help one realize his or her dreams. There are individuals who came into our lives that are believed to be God-sent and they need to be appreciated for the wonderful work and impact that they input into our lives.

Above all, I like to express my gratitude to the Almighty God for providing me with the sound wisdom, knowledge, and energy necessary to complete my final year research and design project, as well as for enabling me to successfully complete my final year project report with a success.

I would like to express my heartfelt thanks to all of the professors and lecturers at the Faculty of Engineering, Design and Technology who shared their ideas with me most especially my project supervisor, **Mr. RODGERS TAYEBWA**, for his patience, direction, consistent attention, informed input, enthusiastic support, and personal assistance throughout the project work.

Special thanks to my parents, **MR. and MRS. WANABADI**, and my academic Sponsor, **DR. ALFRED ACHANDEDE** (Principal and Director of Elgon School of Health Sciences), for their willingness to share knowledge and help during my academic sponsorship

Lastly, I would like to express my sincere gratitude to all of my fellow students and most especially my project partner Bwambale Wilberforce who helped me during research and also with the writing of this report to be a success (GOD bless you all).

APPROVAL

This is to certify that **PETER WANABADI M22B32/034** completed his Research and Design project under my supervision, and the compilation of this project report was completed under supervision and here it is submitted with my approval as part of examination for marking.

MR ROGERS TAYEBWA

Signature - ;

Date- ;/12/2025

DECLARATION

I, **WANABADI PETER** certify that the work contained in this report is based on my own research using various literature reviews and I claim that the statement I've made and the conclusions I've reached are the result of my own work and research. I further declare that;-

The work contained in this report is original and has been done by me under the general supervision of my project supervisor.

The work has never been submitted to any other Institution or University within Uganda or internationally for the same award of Bachelors of Civil and Environmental engineering or any other courses.

Every time I have used information (text, statistics, and theoretical analysis) from another source, I have properly cited them in the report's body and provided their information in the references.

Signature- ;

Date-;/12/2025

Wanabadipeter1@gmail.com

ABSTRACT

Access to safe drinking water remains a challenge to residents of Kisenyi Cell in Namilyango Village where they mainly depend on water from the unprotected Nakyijeera spring. This spring revealed significant microbial contaminations with E.coli and total coliform levels exceeded the WHO and UNBS drinking standards. This study therefore was to investigate the effectiveness of *Solanum incanum* leaf extract as a natural, low-cost disinfectant for water at household level.

Raw water from Nakyijeera spring was analyzed for the physicochemical and bacteriological quality for both the wet and dry seasons. *Solanum incanum* leaves were dried and ground into fine powder, and a stock solution was prepared and examined. Contact time and optimum dosage experiments were conducted at intervals between 0-90 minutes and 0-100ml/l, respectively.

Results showed microbial reduction increased with an increase in contact time and dosage. The contact time was identified as 45 minutes, and the optimal dosage as 40ml/l, achieving 87.5% and 89% reduction for E.coli and total coliform while maintaining pH within acceptable limits. Higher dosage further reduced microbial counts but negatively affected turbidity, pH, and color.

TABLE OF CONTENTS

Contents

ACKNOWLEDGEMENT	i
APPROVAL	ii
DECLARATION	iii
ABSTRACT	iv
TABLE OF CONTENTS	v
LIST OF TABLES	ix
LIST OF FIGURES.....	x
LIST OF ACRONYMS.....	xii
CHAPTER ONE: INTRODUCTION	1
1.0 Background	1
1.1 problem statement	3
1.2 Objectives	3
1.2.1 Main objectives	3
1.2.2 Specific objectives	4
1.2.3 Research questions	4
1.3 Scope of the study	4
1.4 Justification	5

1.5 SIGNIFICANCE	6
CHAPTER TWO: LITERATURE REVIEW	7
2.0 Introduction	7
2.1 Water quality and treatment	7
2.2 Brief background of Nakyijeera spring	9
2.3 Natural coagulants and disinfectant in water treatment	9
2.4 Solanum incanum as natural coagulant and disinfectant	10
2.5 Active components of Solanum incanum	12
2.5.1 Solanum incanum as medicinal plant	13
2.5.2 Disinfection of water	13
2.5.4 Optimum dosage of solanum incanum	15
2.5.5 Coagulation and Flocculation in water treatment	15
2.5.6 Microbiological Efficacy Test.	16
2.5.7 The toxicity of solanum incanum extracts	16
CHAPTER THREE: METHODOLOGY	18
3.0 INTRODUCTION	18
3.1 RESEARCH DESIGN	18
3.2 DETERMINATION OF THE PHYSIOCHEMICAL AND BACTERIOLOGICAL QUALITIES OF RAW WATER FROM NAKYIJEERA SPRING	18
3.2.1 COLLECTION OF THE WATER SAMPLE	18

3.2.2 TURBIDITY (ISO 7027:2016)	19
3.1.3 COLOR (HACH 8025)	20
Procedures	20
3.1.4 pH (ISO 10523:2008).....	20
3.1.5 E-COLI (ISO 9308-1:2014)	21
Procedures	21
3.1.6 TOTAL COLIFORMS (APHA METHOD 9222)	22
3.2 Determination of the optimum dosage of the active components of solanum incanum powder.	23
3.2.1 Materials acquisition	23
3.3 Designing of a suitable water treatment at household level	25
CHAPTER FOUR: RESULTS AND DISCUSSION.....	26
4.0 Introduction	26
4.1 Analysis of microbiological and physio-chemical qualities of the spring water in kisenyi.....	27
4.1.1 pH	28
4.1.2 Temperature.....	30
4.1.3 Turbidity	31
4.1.4 E-Coli (CFU/100ml)	32
4.1.5 Total Coliform (CFU/100ml)	34

4.1.6 Total iron.....	36
4.1.7 Color	36
4.2 Determination of optimum dosage and the active components of solanum incanum L	37
4.2.1 Determination of contact time	37
4.2.2 Determination of optimal dosage	40
4.2.2.1 pH	40
4.2.2.2 Color (PtCo)	41
4.2.2.3 Turbidity (NTU)	42
4.2.2.4 E-Coli CFU/100ml	43
4.2.2.5 Total coliform (CFU/100ml)	44
4.3 Designing of a suitable water treatment unit for water treatment at household level	45
Limitations of solanum incanum for water treatment	47
CHAPTER FIVE: CONCLUSION AND RECOMMENDATIONS	49
5.0 CONCLUSION	49
5.1 RECOMMENDATIONS	50
CHAPTER SIX: REFERENCES	51
CHAPTER SEVEN	55
6.0 APPENDIX	55

LIST OF TABLES

Table 1 materials acquisition.....	24
Table 2 WHO/ UNBS permissible limits for potable water	27

LIST OF FIGURES

Figure 1: Nakyijeera spring	5
Figure 2: Solanum Incanum plant.....	11
Figure 3: pH variation in both seasons	28
Figure 4: Temperate variation in both seasons	30
Figure 5: E-Coli variation in both seasons	32
Figure 6: Total coliform variation in both seasons.....	34
Figure 7: The percentage reduction of E-Coli over contact time	38
Figure 8: Percentage reduction of total coliform over time.....	39
Figure 9: Variation of pH with dosage	40
Figure 10: Variation of color with dosage	41
Figure 11: Variation of turbidity with dosage.....	42
Figure 12: Variation of E-coli reduction with dosage	43
Figure 13: Variation of total Coliform with dosage.....	44
Figure 14: Resident collecting water at the spring.....	55
Figure 15: Preparation of stock solution	55
Figure 16: Preparing of agar	55
Figure 17: Operating a spectrometer	55
Figure 18: Stock solution.....	56
Figure 19: Solanum powder.....	56
Figure 20: Nakyijeera spring.....	56
Figure 21: Sample picking	56
Figure 22: Nakyijeera spring.....	56

Figure 23: Sample picking56

LIST OF ACRONYMS

CFU	Colony Forming Units
COD	Chemical Oxygen Demand
DO	Dissolved Oxygen
NTU	Nephelometric Turbidity Unit
PH	Potential of Hydrogen
UV	Ultraviolet
TDS	Total Dissolved Solids
TSS	Total Suspended Solids
WHO	World Health Organization

CHAPTER ONE: INTRODUCTION

1.0 Background

Access to a safe and clean water supply is a universal human right and a fundamental aspect of public health, socio-economic growth, and environmental conservation, consistent with Abraham Maslow's Hierarchy of Human Needs. Water is necessary for various purposes such as domestic use, agricultural use, drinking, and many others. Nonetheless, an estimated 2.2 billion individuals have no safe supply of drinking water (WHO, 2022). It is worse in the developing regions where the water sources are contaminated and water service and water distribution networks are not well established.

In Africa, more than 400 million people rely on natural water sources like surface water (lakes and rivers), springs, and wells for their daily water requirements (Singh, 2024). These sources are highly susceptible to contamination from agricultural runoff, municipal effluents, poor sanitation practices, and industry effluents and these cause infiltration into underground water sources leading to contamination which in turn possess a significant health risk to individuals utilizing such water sources (Singh, 2024).

In Uganda, despite of the efforts being taken by the Government through its agencies like the National Water and Sewerage Corporation under the Ministry of Water and Environment, there is a continued challenge for the accessibility of safe and clean potable water especially to especially to individuals living in per-urban and rural areas of Uganda (MWE 2020). According to the Water and Environmental Sector

Performance Report for 2020, an approximation of 39% of Uganda's rural population currently depends on natural water sources including water from springs, and surface water for domestic consumption (Ministry of Water and Environment, 2020). While springs are regarded as a comparatively safer option for potable water by residents, they are susceptible to contamination particularly in situations where sanitation facilities for solid waste disposal are poor and uncontrollable runoff of storm water (Singh, 2024).

For Namilyango Village, in Kisenyi Cell, Mukono District, the inhabitants draw water from natural and unprotected springs like (Nakyijeera spring) for drinking, cooking, and other household duties. As a result of a favorable location of the spring, it is highly accessible and hence favored by residents and the neighboring population for water collection. Nonetheless, the spring is still at risk of contamination from surface runoffs, farmland effluents, and infiltration from the adjacent regions (MWE 2020).

Traditional water treatment methods in most times leads to a financial burden to low-income families/ earners and thereby spurring into a related interest in locally available, natural, low-cost, and environment-friendly alternatives. The primary focus of the study was determining the effectiveness of *Solanum Incanum* in the treatment of bacteriologically contaminated water at household level in Namilyango Village, Mukono district since it has proven abilities and potential to disinfect water against pathogens (Rani et al., 2025).

1.1 problem statement

Residents of Kisenyi Cell, Namilyango village in Mukono district still rely on water from springs as their main source. The spring is unprotected and highly contaminated with excessive iron concentration of 1.55 mg/L, and significant microbial contamination of E-coli 16 CFU/100L and total coliform of 48 CFU/100L. These exceeds the East African potable water standards and they pose a serious health risks linked to waterborne diseases particularly to these users where access to conventional water treatment methods and chemicals are limited due to high costs and un available for household level treatment (Kihampa et al., 2011) (EAS12; 2018). The dependency on untreated water has exacerbated the burden of water-related illnesses which is threatening the community's well-being (WHO/UNICEF, 2023). This therefore calls for urgency to identify the locally available and affordable water treatment method at household level as this study is to assess the use of *Solanum incanum L* as a natural coagulant and disinfectant in the treatment of bacteriologically contaminated since it showed promising potentials for improving water quality by reducing turbidity and removing microbial contaminants in water for portability (Kihampa et al., 2011)

1.2 Objectives

1.2.1 Main objectives

To assess the use of *Solanum incanum L* in the treatment of water at household level

1.2.2 Specific objectives

1. To determine the physicochemical and bacterial quality of raw water from Nakyijeera spring
2. To determine the optimum dosage of the active components of *solanum incanum* powder
3. To design a suitable water treatment unit for water treatment at household level

1.2.3 Research questions

1. What is the physicochemical and bacteriological quality of raw water from Nakyijeera spring (temperature, pH, E-coli, total coliform, total iron, Color, and turbidity)?
2. What is the optimum dosage of the active components of *solanum incanum* powder?
3. How effective is the water treatment unit at household level?

1.3 Scope of the study

The scope of this study is on Nakyijeera spring in **Kisenyi Cell**, Namilyango village, Mukono Municipality in central region of Uganda at coordinates 0°20'03.2"N 32°42'40.8"E

At elevation ranging from 1134m to 1299 above sea level



Figure 1: Nakyijeera spring

1.4 Justification

Access to clean and safe drinking water is one of the most fundamental rights to human health. In Kisenyi Cell, residents rely on unprotected and contaminated water from Nakyijeera spring as their main source of potable water for home consumption and drinking which possess a serious risk on their health and lives. The level of contamination exceeds the limits set by the East African potable water standards and Uganda's regulations (UNBS, 2018; WHO, 2022). In low income and informal settlements, the conventional water treatment methods like use of alum, ferric salts, and chlorine are often costly, unavailable, and impractical at household level for water treatment (Onyutha & Auma, 2023); WHO/UNICEF, 2023). This therefore calls for the indigenous, affordable and environmentally friendly alternative method for water treatment. *Solanum incanum*, a plant native to East African, has proven and demonstrated its strong ability/potential as a coagulant and disinfectant in water treatment (Kihampa et al., 2011). Its leaves contains bioactive compounds like

steroids ($C_{27}H_{42}O_3$), alkaloids and flavonoids($C_{15}H_{10}O_7$) that have shown the ability to reduce both the turbidity and eliminate microbial pathogens from contaminated water through coagulation and flocculation mechanisms and antibacterial actions (Kihampa et al., 2011) and (Waithaka et al., 2019). It has been proven with a possibility of removing up to 99% of turbidity and significantly lowering the microbial counts in water when methanol is used in the preparations (Waithaka et al., 2019). Additionally it has the ability to outperform alum at a lower dosage in removing particulates which further validates its practicality and affordability in water treatment (Waithaka et al., 2019).

In the community's pressing need, this research was justified as a timely and essential exploration of other alternatives of water treatment strategy. By evaluating the effectiveness of *S. incanum L* at household level, it was not only addressing the documented public health crisis but also aligned with the global priorities under Sustainable Development Goal 6.1 which aims in ensuring universal access to safe, clean and affordable drinking water to everyone (WHO/UNICEF JMP, 2023). This was also aimed at promoting community empowerment, environment sustainability and integration of indigenous knowledge into health focus interventions.

1.5 SIGNIFICANCE

This research study was expected to add on the existing knowledge about water treatment using low cost but effective material at household level.

CHAPTER TWO: LITERATURE REVIEW

2.0 Introduction

Water contamination is the one of the most significant issues in developing countries like Uganda since most individuals especially in pre-urban and rural areas depend on water from untreated sources like springs, wells and surface water. Most of these sources are contaminated with bacteria like E-coli, and shigella species which are harmful to human health (Adomi Mbina et al., 2020). The aim of this literature review was to give detailed information about the study and application of natural coagulants and disinfectants in water treatment. The main focus was on the use of *S. incanum* as a natural coagulant and disinfectant in the treatment of contaminated underground/ Nakyijeera spring water.

2.1 Water quality and treatment

Clean water is important for human health worldwide. However, ground water sources are continuously being contaminated with suspended particles, pathogens, organic debris, and heavy metals most especially in underdeveloped countries like those in sub Saharan Africa (WHO, 2017). These contaminations are normally as a result of agricultural runoff, industrial discharge, infiltrations and surface runoff, and leaching from landfill (WHO, 2017). In places like those in urban slums and rural areas, giving an example of kisenyi settlement area in Namilyango village, Mukono District, the contamination of Nakyijeera spring water is as a result of surface ran off from nearby agricultural fields, infiltration from pit latrine and poor solid and water waste management (Sanny 2025). For this reason, water treatment is very important

in ensuring that drinking water satisfies the World Health Organization (WHO) guidelines and national standard requirements. The treatment methods that are standard consist of phases that start with coagulation, flocculation, and then proceed for sedimentation, filtration, and disinfection. Coagulation helps in the removal of most of the suspended solids and turbidity that harbor a lot of the microbes, looking at the aspect of chemical coagulants like alum, ferric chloride, ferrous sulfate, which are frequently utilized because they are effective in destabilizing and aggregating the colloidal particles (WHO, 2017). Disinfectants like chlorine help in destabilization and killing harmful micro-organism like viruses and parasites. However, these coagulants and disinfectants are costly, especially in rural areas. In addition to that, research shows that long-term exposure to residual alum in treatment of water has been related to some neurological illnesses, which include Alzheimer's (Choy et al., 2014). And furthermore, the usage of chemical coagulants results in the generation of non-biodegradable sludge, which causes environmental problems. This leaves the researchers at the aspect of looking at naturally occurring, low-cost, biodegradable and sustainable alternatives that can also do the same work as the chemical coagulants, taking us to a deep dive into natural coagulants.

Water treatment refers to the process of improving the quality of water for the purpose of meeting the desired end use for example drinking and disposal both the physiochemical and bacteriological by eliminating the possible contaminants that are harmful to human health and the environment (Pakharuddin et al., 2021).

2.2 Brief background of Nakyijeera spring

Nakyijeera spring is found in Kisenyi Cell in Namirango village located in Mukono District at coordinates 0° 20'03.2"N 32° 42' 40.8"E and elevation ranging from 1134 m to 1299 m above sea level.

The spring was constructed in 2012 by locals, spearheaded by LC 1 at the time when the population was minimal to an approximate of 100 people. In the construction process, materials and equipment like hard core, plastic containers and concrete were used and it was set up to a depth of 3 feet below the ground level.

The spring was identified as a case study after careful observation of the community's health records and after obtaining the records and accompanying with water sampling and testing. The major cause of the contamination of the spring was identified as the presence of open defecation, infiltration from pit latrine and leaching from wastes and also discharges from agricultural fields.

2.3 Natural coagulants and disinfectant in water treatment

Natural coagulants are those obtained from biological resources, primarily plant extract (plant leaves, plant seeds, steams, fruits and roots) which are gaining popularity as environmentally friendly alternatives to artificial coagulants (Koul et al., 2022). Looking at different research, different plants have been found with the ability to coagulate, for example, Moring oleifera which can effectively remove turbidity, color and other contaminates at a range of 50%-98% turbidity removal, cactus, among others. Such materials are affordable by the populations that have a limited resource, since they are biodegradable and non-toxic, and generally readily available. In

addition to that, natural coagulants produce lower sludge volumes, making them easier to utilize and more environmentally friendly (Hadadi et al., 2022). These chemicals can destabilize the colloidal particles in water using mechanisms like charge neutralization, adsorption, and bridging flocculation (Shahzadi et al., 2024).

2.4 *Solanum incanum* as natural coagulant and disinfectant

Solanum incanum is a scientific name with a common English name as Sodom apple which is a wild, perennial shrub belonging to the Solanaceae (nightshade) family (Rani et al., 2025). It is native to Africa, Middle East and south and Southeast Asia, including countries such as India, Iran, Afghanistan and Pakistan (Rani et al., 2025). The plant typically grows between 0.4-1.5 meters tall in disturbed soils (over grazed and along road sides) and is characterized by the prickly stems, stellate-hairy leaves and purple-blue flowers and its fruit is globose yellow berry containing pale-brown and kidney shaped seeds and it's about the diameter of 2.0-3.0cm (Rani et al., 2025).

In the process of sustainability and accessibility of water treatment solutions, *solanum incanum* has a promising natural coagulant and disinfectant characteristics that are suitable for rural and resource scared communities (Rani et al., 2025). Native to African and other parts like Asia and India, this wild medicinal shrub has been recognized for its therapeutic properties. Recent research has expanded its relevance in environmental engineering, demonstrating its efficiency in the improvement of water quality by coagulating and reduction of microbial contaminates (African Journal of Environmental Science and Technology, 2011). *Solanum incanum* has a rich composition of bioactive compounds like alkaloids (0.6%), flavonoids (26.7%), tannins

and saponins (14.4%). Most of these active compounds play an important role in the destabilization of suspended particles in water treatment facilitating the formation of flocs and sedimentation (Karanja et al., 2021) and (Al-Shehri et al., 2022). The presence of proteins in plant is reported to be the main component that is responsible for the coagulation and flocculation processes in water treatment, it is also reported in various literature that plant species have the capability to reduce turbidity provided it is used at optimum dosage (Moa Megersa, 2014).

Previous studies have shown that optimal concentration of active components in *Solanum incanum* can reduce turbidity up to 97% and eliminate fecal coliform by 99% as the plant showed low toxicity in the effective dosage and these meet both the World health Organization guidelines (WHO) and the national standards in water treatment (Waithaka et al., 2019).



Figure 2: Solanum Incanum plant

2.5 Active components of *Solanum incanum*

The primary active components in *Solanum incanum* are found in various parts of the plant with higher concentrations being observed in unripe berries, these includes the glycoalkaloids comprising of the Solasonine, solamargine, and solanine which are able to exhibit cytotoxic properties that can disrupt microbial cell membranes and growth (Manoharan et al., 2024). There are also flavonoids which are present in leaf and root extract and they have demonstrated effectiveness against both the gram positive and gram negative bacteria, these compounds exert their antibacterial effects by interfering with germ activities like nucleic acid synthesis and altering cell membrane permeability (Manoharan et al., 2024). Tannins and other compounds like phenolic are present in *solanum incanum* which help contribute antiseptic and astringent properties that hinder microbial growth and potentially prevent biofilm formation (Rani et al., 2025).

The choice for solvent for extracting the active compounds can significantly impact their concentration and efficiency as research has shown that organic solvents like ethanol and methanol are generally more effective in extracting wider range of bioactive agents from *solanum incanum* compared to water, because plant's antimicrobial constitutes alkaloids and flavonoids which are more soluble in alcohol based solvents and so ethanol extracts on leaves for instance have shown particularly strong antibacterial activity against pathogens like E-coli and s. aureus resulting in larger inhibition zones in laboratories (Sbhatu & Abraha, 2020).

The combination of these various active components in leaves of *solanum incanum* has a broad spectrum of disinfecting capabilities as glycoalkaloids are central to antimicrobial effect, synergistic effects of other phytochemicals enhance the plant's potentials to inhibit and eliminate a variety of waterborne pathogens and these complex biochemical profiles underpins the plant's traditional use as medicinal and promises us as a natural water treatment option (Jan et al., 2024).

2.5.1 Solanum incanum as medicinal plant

There is an estimate of almost 80% for the world's population depending on the utilization of herbal medication in the treatment of illnesses and diseases, and natural products are preferred over the manufactured ones (WHO). *Solanum incanum* has the effects of antiulcer genus which was studied by assessing antiulcer activity of extracts from *s. incanum* roots and leaves (Lashin et al., 2021). There are also effects like analgesic effects, anti-tick effect, nematocidal activity, and spasmolytic effects and the phytochemical present in *s. incanum* fruit includes the alkaloids, cyanogenic, cardiac glycoside, flavonoids, saponins, steroids and tannins are responsible for the pain killer effects, disease like wounds, hemorrhoids and burns can be treated with plants having those mentioned phytochemical compounds according to (Rani et al., 2025).

2.5.2 Disinfection of water

Disinfection of water is the process of destabilizing, inactivating and destroying the cell membrane of pathogens in water that has gone through the treatment stages and other contaminants like suspended particles have been filtered off (WHO, 2022) and it

the final stage in water treatment with the primary goal of eliminating waterborne diseases causing germs and making water safe for human consumption (Pontius, 2003).

Disinfection of water can be achieved through the use of chemical or physical methods like the ultraviolet (UV) irradiation, boiling and solar disinfection but these lack residual protections (Clasen et al., 2007). Chlorine is the most common convection method and is a chemical method of water disinfection because of its high effectiveness and residual protection in the distribution system. The efficiency of a disinfectant depends on the concentration, contact time, pH, temperature turbidity and pathogens present (EPA 2021).

2.5.3 Contact time

Contact time can be defined as a period during which water remains in contact with a disinfectant to interact with the active antimicrobial components and it is affected by flow rate, tank design, temperature and pH of the water and the type of a disinfectant and it is one of the most important parameters influencing the efficiency of natural treatment processes (WHO, 2022).

Bioactive compounds of *solanum incanum* such as alkaloids, tannins, flavonoids, and terpenoids require enough time to interact with suspended particle to neutralize their surface charge. This promotes particle aggregation and floc formation which in turn improves the turbidity and color of water (yin, 2010). The laboratory studies commonly tested intervals such as 0, 15, 30, 45, 60, 75, and 90 minutes for the determination of optimal contact time for natural disinfectants.

2.5.4 Optimum dosage of solanum incanum

Optimum dosage of a natural disinfectant is referred to as the minimum quantity of plant extract that achieves the maximum turbidity reduction and microbial inactivation in the treatment of water. In practical knowledge, the optimum dosage is assessed through the jar test experiment for coagulation where different chemical concentrations are applied to water samples of known turbidity and microbiological levels. The treated sample is then analyzed for turbidity, pH, microbial counts and other parameters to see if the potable water standards are met by the guidelines set by the world health organization. For the disinfectants, it is important to determine the contact time to which a certain dosage will still be active.

2.5.5 Coagulation and Flocculation in water treatment

Coagulation is the process in water treatment that helps in the removal of particles, colloids and other impurities from water with the addition of specific chemicals (coagulants) to destabilize and aggregate suspended particles for easy removal by gravity through sedimentation and filtration. Colloidal particles that are present in water are mostly negatively charged causing mutual repulsion and preventing them from natural settling by gravity (Thorat et al., 2020). Chemical coagulants such as aluminum sulfate (alum) and ferric chloride are widely used due to their high efficiency and availability however, their cost, residual toxicity and sludge production has led to the interest to dive into natural alternatives like solanum incanum powder, molinga oleifera seeds powder in water treatment (Benalia et al., 2024).

After coagulation, it was followed by the process of flocculation which can be defined as the process of gentle mixing to increase fine particles forming larger clumps called flocs that can settle at the bottom due to gravitational forces. This process is achieved by adding specific chemicals called flocculants or coagulant aids which work by neutralizing the electrical charges of those particles in water.

2.5.6 Microbiological Efficacy Test.

One of the best ways to determine the optimum dosage for our active components of *Solanum incanum* is by performing a Microbiological Efficacy Test. In this experiment, ten beakers are set up with a raw water sample of raw water dosed with stock solution from 0 ml, 10 ml, 20 ml, 30 ml, 40 ml, 50 ml, 60 ml, 70 ml, 80 ml, 90 ml, and then 100 ml. The first glass beaker was for a control experiment and the rest are dosed with different amounts of chemicals as expressed above. The experiment is run for a specific contact time in minutes.

The biological qualities of water are determined before and after treatment at the end of the set contact time and graphs of contaminants reduction against contact time are plotted and then the optimal dosage is determined at a point of no further reduction in the contaminants.

2.5.7 The toxicity of *Solanum incanum* extracts

Solanum incanum is a toxic plant to the animal, livestock and humans as it contains compounds that can cause illness or death (Mwaura et al., 2015). The toxicity can lead to abdominal pain, nausea and digestive tract damage to humans and can also be a threat to livestock and an invasive weed in some environmental conditions (Mwaura

et al., 2015). This therefore calls for detoxifying *solanum incanum* so that the portability of water does not cause any further health complications to human lives. Detoxifying of *solanum incanum* is mainly aimed at reducing or eliminating the alkaloids from the extract while retaining the disinfecting components which are the antimicrobial. The common methods of disinfecting are;-

Drying and grinding;- The leaves were both air and oven dried at moderate temperature (40-60°C). To reduce the moisture content that is responsible for holding toxins,

Washing or soaking;- Some ant nutrients and toxins are water soluble meaning they can be removed through washing/ soaking, Solvent extraction since the choice of solvent used extraction process can influence the detoxification of the toxic plant extracts (Sambo et al., 2016).

CHAPTER THREE: METHODOLOGY

3.0 INTRODUCTION

This chapter covers the specific procedures and methodologies that were followed in determining the qualities of raw water, powder preparation /disinfectant, and experimental set ups and procedures to achieve the set objectives of the research. Coagulation is important for neutralizing the negative charges of colloidal particles in water so that agglomeration is enhanced for water quality and improvement. Therefore the purpose of this chapter is to ensure that the research is systematic and scientifically credible.

3.1 RESEARCH DESIGN

The research followed a systematic procedure guided by previous studies about the application of natural disinfectant in improvement of the bacteriological qualities of raw water from Nakyijeera spring in Kisenyi Cell Mukono District.

3.2 DETERMINATION OF THE PHYSIOCHEMICAL AND BACTERIOLOGICAL QUALITIES OF RAW WATER FROM NAKYIJEERA SPRING

3.2.1 COLLECTION OF THE WATER SAMPLE

Following the standard operating procedures for sample collections, safety gears were first prepared to prevent the recontamination of water from the external surroundings and the surrounding conditions like mist, fog and dust were observed and on such days water was not collected since they could lead to more contamination of the collected water sample.

Clean plastic sampling bottles were obtained and were further cleaned using distilled water to prevent further contamination while picking the water samples.

A cooler box was obtained, which helped in keeping the sample at a temperature that favored the life of bacteria from multiplying or dying off and thus preventing sample deterioration.

On arrival at the water source, the sampling bottles were rinsed using the raw water from the Nakyijeera Spring, and then water samples were collected in triplicates and in situ parameters like pH and temperature was measured.

The sample was then transported to the laboratory for analysis. For the bacterial aspect, the tests were carried out within 6-24 hours to ensure accurate results and also to avoid the sample deterioration.

3.2.2 TURBIDITY (ISO 7027:2016)

Turbidity is the measure of the cloudiness of the water caused by suspended particles. High turbidity may indicate the presence of suspended solids, microorganisms, or other contaminants that reduce water quality and interfere with disinfection processes. Knowing its level is really important, as it correlates with particulate-related microorganisms. For this case, the Nephelometric method was used where turbidity meter was used to measure how much light was being scattered by particles in water. The turbidity meter was first calibrated using distilled water and then inserted in to the water sample. The results were reported in Nephelometric turbidity units (NTU) with the acceptable limit not exceeding 5 NTU by World Health Organization and the national standards.

3.1.3 COLOR (HACH 8025)

Looking at the spring, the presence of unusual colour could strongly suggest the presence of decaying organic matter and other contaminants in the water. As we checked for colour, we were able to know the kind of suspended particles that are in the Kisenyi spring water.

For the measurement aspect, a colorimeter was used to measure colour in True Colour Units (TCUs).

Procedures

- ✓ The spectrometer was calibrated to ensure that it could work based on the required laboratory testing standards.
- ✓ The sample was placed in a clean sample cell and then inserted in the colorimeter/ spectrometer and read button pressed.
- ✓ The reading was read off from the screen of the spectrometer and recorded as PtCo.
- ✓ The experiment was repeated in triplicates and then averaged.

3.1.4 pH (ISO 10523:2008)

PH is the acidic or alkaline of water and it makes the water unsuitable for consumption and also influences the survival rate of bacteria in the water and the effectiveness of water treatment. Therefore, finding out the pH level of water is very important.

Procedure

- ✓ The calibrated pH electrodes were immersed in the water sample, and then waited for the pH reading to stabilize, just for a minute.
- ✓ The pH value displayed on the meter will then be recorded (we will ensure that the electrode is fully submerged, not touching the bottom or the sides of the sampling bottle or container.
- ✓ The electrode will then be rinsed with distilled water to avoid contamination.
- ✓ The measurements were repeated two more times to ensure accuracy.

The WHO guideline for pH in drinking water is 6.5 - 8.5 with scale running from 0-14 and pH is unit less because it's a logarithmic scale and not direct measurement.

3.1.5 E-COLI (ISO 9308-1:2014)

E-coli are a type of bacteria that can be found in the intestines and feces of warm-blooded animals and humans. They are a measure of faecal contamination in water and are measured in CFU/100mL.

Apparatus used: Incubator, membrane filtration unit and disinfected forceps, culture media, and reagents like MacConkey agar.

Procedures

- ✓ The collected water samples were filtered through a membrane filter unit
- ✓ MacConkey agar was prepared according to the manufacturer's instructions and placed on petro dishes before solidifying. MacConkey agar is a selective culture medium for isolating E-coli.

- ✓ The membrane filtration was carried out by placing filter paper on the sterilized filter unit and sample passed through. The filter paper was then transferred to a MacConkey agar plate.
- ✓ The membrane filter was placed on an agar plate which was then incubated at 36°C for 24 hours.
- ✓ After 24 hours, the chromogenic coliform agar plate was then removed from the incubator, and the colonies were counted.

3.1.6 TOTAL COLIFORMS (APHA METHOD 9222)

The purpose of testing for total coliforms is to determine the presence of bacterial contamination, which may indicate faecal contamination which is a potential health risk to human lives. The tests were performed using the Membrane Filtration Method, where a water sample was passed through a 0.45 µm membrane filter to trap bacteria.

The filtrate was then transferred to an agar plate containing red violet agar incubated at 35-37°C for 24 hours. Coliform colonies were then counted and reported as CFU/100 ml.

3.2 Determination of the optimum dosage of the active components of *solanum incanum* powder.

To obtain the active components or disinfectant of *solanum incanum*, the following steps were followed;-

- ✓ Leaves were obtained from Kisenyi Cell along the railway and cleaned to remove contaminants like dust and other fallen materials.
- ✓ Leaves were dried to remove moisture content in them so there is no interference during the powder making process and this helps in storage and longer preservation period.
- ✓ The leaves were grinded in grinder, sieved to remove coarse particles for uniform texture and uniform cross sectional area and then stored for further analysis
- ✓ 100 grams of fine powder was infused in 50 ml of methanol for 10hours to ensure well dissolution of the powder
- ✓ The solution was then filtered using whatman No 1 filter paper thereafter the concentrated filtrate was then evaporated to obtain the concentrated extract which was then stored for further analysis in water treatment

3.2.1 Materials acquisition

Raw water was obtained from Nakyijeera spring in Kisenyi Cell in the morning hours since the microbial contamination was high during those hours of the day and this was done on different days. Leaves of *Solanum incanum* were also obtained at a free cost

along the road and railway reserves and disturbed farm lands in Kisenyi cell Namilyango village in Mukono District.

Table 1 materials acquisition

Item	Method of acquiring	Location	Cost of acquisition
Mature <i>Solanum</i> leaves	Picking from <i>solanum</i> plants	Road reserves, disturbed farm lands, and railway reserves	Free
Raw water sample	Nakyijeera spring	Kisenyi Cell	Free
Oven	Hire	Campus laboratory	At a cost
Sieve	Buying	market	At a cost
Grinder/ blender	hire	Friend	At a cost

The material was grinded in a blender to obtain the powdered and to obtain an optimum dosage of *Solanum incanum* powder, the steps below were followed;-

- ✓ Stock solution was prepared with different concentrations of *solanum incanum* powder using distilled water.
- ✓ Depending on preliminary tests, different solutions were prepared with different dosage of *solanum incanum* powder and placed in 1000 ml jar of raw

water (0 mL, 10 ml, 20 ml, 30 ml, 40 ml, 50 ml, 60 ml, 70 ml, 80 ml, 90 ml and 100 ml).

- ✓ The mixture was allowed to settle for different contact times 0, 15, 30, 45, 60, 70, and 90 minutes.
- ✓ The measurements for efficiency were then determined through measuring the bacteriological qualities of water (E-coli and Total coliform) and other physiochemical qualities were also determined.
- ✓ The results were plotted as dosage on y-axis against microbial reduction on x-axis as they will be discussed in the next chapter.

3.3 Designing of a suitable water treatment at household level

With reference from the water supply design manual 2013 and through interviews conducted in Kisenyi Cell Namilyango village, water demand was computed and treatment unit designed and prototype made.

CHAPTER FOUR: RESULTS AND DISCUSSION

4.0 Introduction

This chapter is where all result recorded after sampling water from Nakyijeera spring during the two seasons are discussed for both the treated and untreated water obtained from the spring. Solutions were provided to the identified objectives and the research questions following the methodologies in chapter three. For the analysis of physio-chemical qualities, the tests were carried out in triplets for each dataset (morning, afternoon and evening) and average value obtained and plotted on groups and these helped in providing understanding and variations of how the water was contaminated and at which time of the day is the contaminations less concentrated and why. The physiochemical and bacteriological qualities of raw water from Nakyijeera spring was sampled in variations of wet and dry season after careful study of the seasonal calendar of the region (central region) from ministry of Water and Environment (MWE, 2025).

Table 2 WHO/ UNBS permissible limits for potable water

Parameter	Units	WHO limits	Preliminary findings from the spring
E-Coli	CFU/100ml	<1	18
Total coliform	CFU/100ml	<1	48
Turbidity	NTU	<25	0.0
pH	-	6.5-8.5	6.2
Color	PtCo	<50	0
Total iron	Mg/l	<0.3	0.01

4.1 Analysis of microbiological and physio-chemical qualities of the spring water in kisenyi

Raw water was extracted from the Nakyijeera spring using clean sterilized plastic bottles, placed in a cooler box containing ice blocks and sampling was done at three different times within the day (morning, afternoon and evening) for a single data set and then transferred to the laboratory for analysis. This was done in three datasets for the wet and dry seasons and a single data set done for morning, afternoon and evening.

There was an increase in the E-coli and total coliform in the wet season because there was increased run off, infiltration rate and leaching of surface water into the ground which carried the bacteria into the ground aquifer from dump sites, pit latrines, open defecation areas. The presence of Total coliform and E-coli indicates the

contamination of the water source with fecal coliform/ matter from humans and livestock and these may cause a serious health risk to humans. The pH was in a range of 6.27 and 6.90 which is almost an ideal pH for supporting life.

Turbidity and color did not change because there was no eroding of surface water into the aquifer recharge and discharge points. High turbidity indicates the presence of contaminants and high color as they are discussed below.

4.1.1 pH

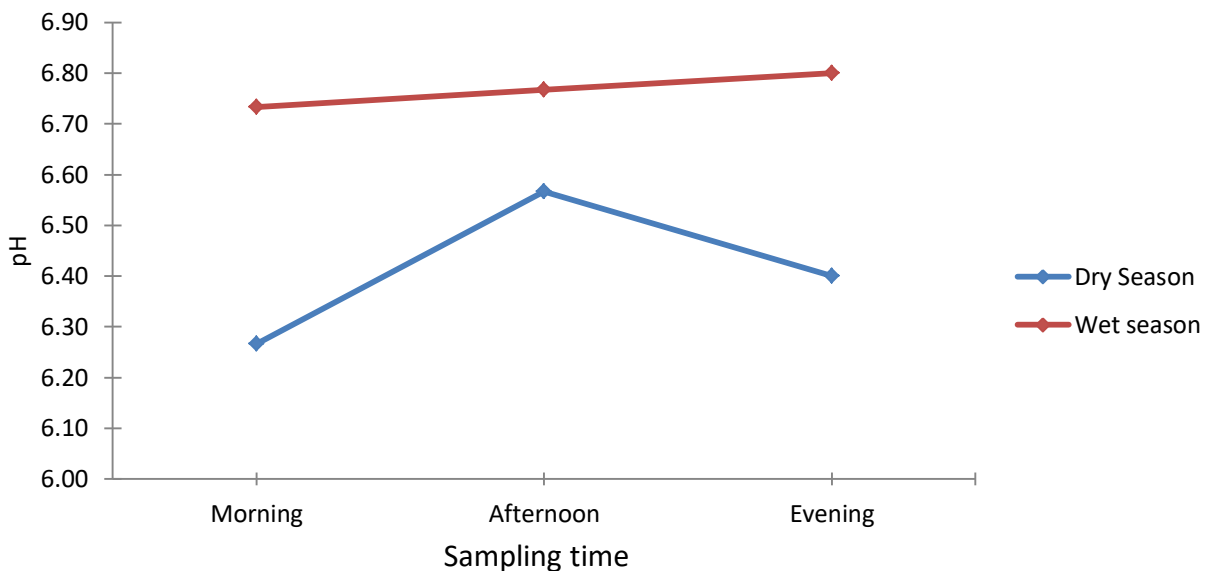

Figure 3: pH variation in both seasons

pH is the measure of acidity or alkalinity of any solution in water and it has no units because it is defined as a logarithmic function of ratio, rendering it dimensionless. Mathematically, $pH = -\log(H_3O^+)$. Computation for pH must be converted to hydrogen ions to obtain the means and then converted back to pH values.

During the sampling and testing for water at different periods of the day (morning, afternoon and evening), the pH of the water was discovered to be in the range of 6.27 and 6.67 for the morning, afternoon and evening respectively.

The pH for morning was 6.25 because of low photosynthesis in the early morning and higher carbon monoxide concentration that was produced overnight and cooler temperatures which caused the pH to become slightly acidic. During the afternoon, the pH increased due to increased photosynthesis, temperature increase and evaporation effects and it further dropped to 6.40 in the evening because there was decline in photosynthesis, carbon monoxide accumulation resumes in the dry season.

These pH values are not in the range of potable water standards ranging from 6.5 - 8.5 apart from the afternoon which was recorded as 6.55 which can support life of organisms.

During the wet season, the pH range was recorded as 6.73 and 6.80 which were in the recommended range of 6.5 and 8.5 favorable for the life of living organisms and human life. Lower pH is acidic and can lead to death of micro-organism and in human, it can cause skin and mucous membrane irritation, gastrointestinal issues and it can also leads to the corrosion of pipes, disrupt the ecosystem as it alters its balance leading to species changing their composition. Higher pH can also lead to nutrient deficiency for plants, scaling on infrastructure and can lead to ion imbalance in water.

Low levels of pH were observed during the morning sampling due to the accumulation of carbon monoxide overnight which forms carbonic acid and hence decreasing the pH.

The pH is 6.70 in the morning because of the dilution from rainfall and less carbon monoxide, raises for the afternoon to 6.75 due to moderate photosynthesis and stable temperature and it further reaches 7.80 in the evening because of lower biological stress and buffered system.

4.1.2 Temperature

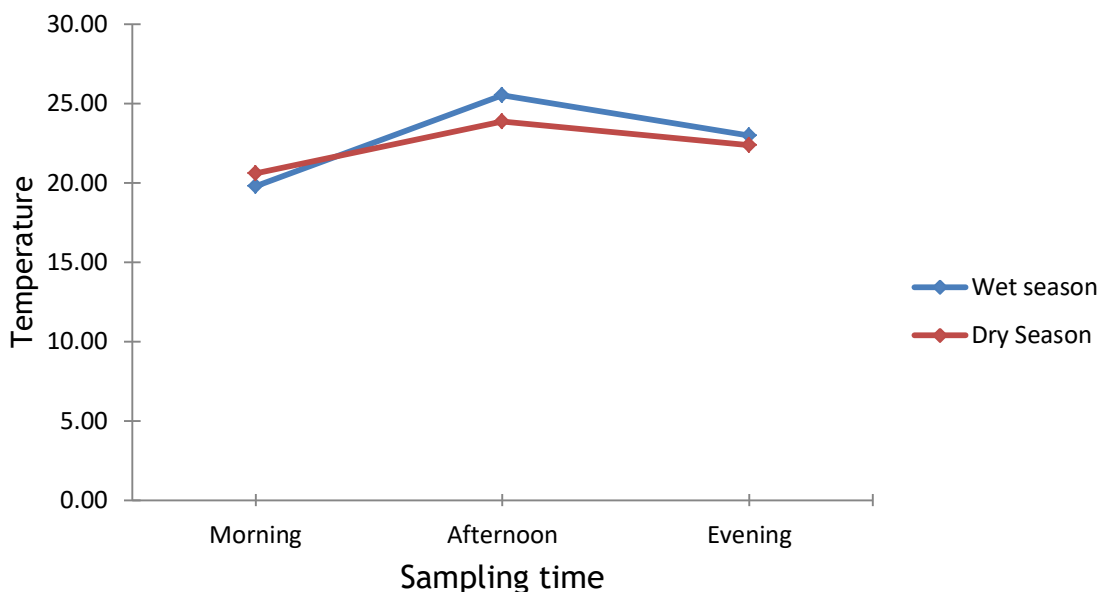

Figure 4: Temperate variation in both seasons

Temperature is the measure of how hot or cold an aquatic body may be and it was measured in degree Celsius ($^{\circ}\text{C}$). After sampling in the morning, afternoon and evening in the dry season, the temperature was recorded as 18.33 ± 0.58 $^{\circ}\text{C}$, 21.17 ± 2.02 $^{\circ}\text{C}$ and 22.37 ± 0.23 $^{\circ}\text{C}$ respectively. And in the wet season, we obtained readings of 19.80 ± 2.85 $^{\circ}\text{C}$, 25.50 ± 4.12 $^{\circ}\text{C}$, and 22.97 ± 4.43 $^{\circ}\text{C}$ for morning, afternoon and evening respectively. The temperature in ground water is influenced by the

geological factors like depth of the aquifer and its properties, rock type, the hydrological factors like the recharge rate of the aquifer, surface interactions and the ground water flows. The temperature can affect the dissolved oxygen in water as higher temperatures can reduce the dissolved oxygen and hence leading to the reduction of micro-organisms living in an aquatic environment. Lower temperature in water leads to micro-organism to be preserved for a longer time as it is an ideal for preservation but not reproduction. Higher temperatures in the wet season were as a result of reduced evaporation which leads to cooling of the water body, solar radiation absorption even when clouds block sun light, regional climate dynamics and high humidity. In the evening, the subsurface retained the heat that had been absorbed during the day, causing the groundwater to release the stored heat as it flows to the spring gradually. That's why the temperatures decline slowly rather than a sharp drop. (Taylor & Howard, 1996).

4.1.3 Turbidity

Turbidity is the measure of clarity of water or the degree at which light is blocked from passing through water causing muddiness or cloudiness. This can be caused by dissolved solids like mud and chlorophylls due to broken branches and leaves falling in water bodies. Increasing turbidity can lead to absorption of sunlight by particles leading to warming of water bodies. During the dry seasons, the turbidity was 0 NTU and during the wet season, we also recorded the turbidity to be 0 NTU because the run off was not present and low rate of infiltration. Despite turbidity being 20 NTU during the preliminary testing, it was later discovered that it had due to heavy rains

that caused flooding a day before preliminary sampling was carried out which resulted in high turbidity values.

4.1.4 E-Coli (CFU/100ml)

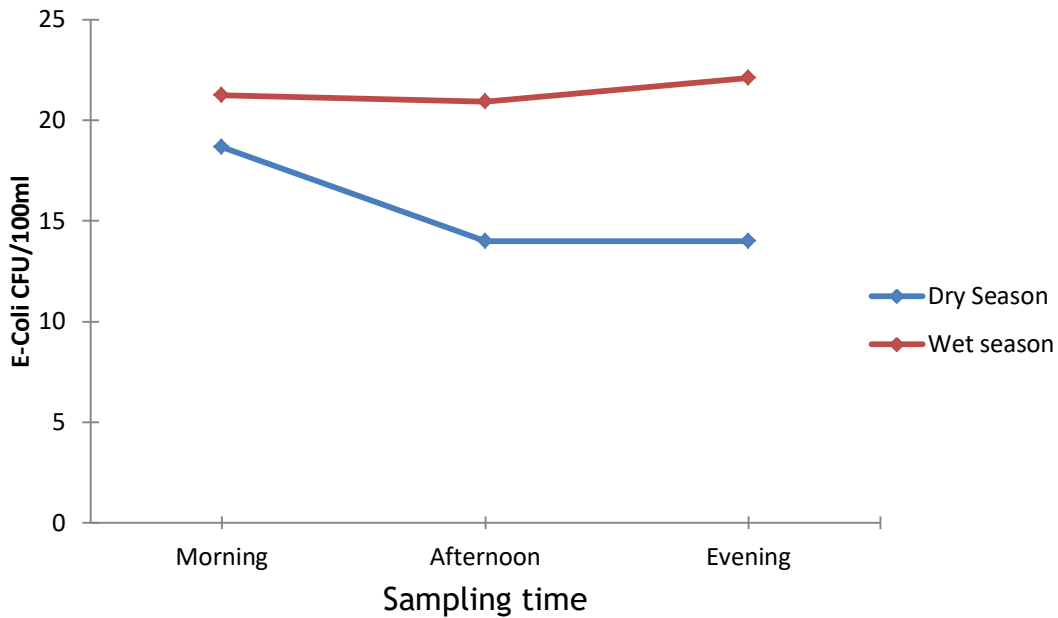

Figure 5: E-Coli variation in both seasons

E-coli is a type of bacteria that lives in many places in our environment including the gastrointestinal systems of humans and warm blooded animals and it's measured in CFU/100ml. E-coli can grow on a solid or liquid medium under laboratory conditions and may be grown in a basic minimum of media which includes glucose as a carbon and energy source, ammonium salts and other salts as nitrogen sources (Basavaraju & Gunashree, 2023).

From the laboratory results obtained from sampling of water, it was discovered that E-coli ranges from 18 CFU/100ml, 14 CFU/100ml and 14 CFU/100ml for morning,

afternoon and evening respectively and this was done during the dry season. During the wet season, the morning, afternoon and evening gave us a recording of 21 CFU/100ml, 21 CFU/100ml and 22 CFU/100ml respectively. They are all above the recommended standards for potable water by both the international and national standards which must be 0 CFU/100ml.

In the morning, the temperature is favorable but there is competition of nutrients and increased die off of pathogens due to high carbon dioxide produced over night.

In the afternoon, there is favorable high temperature for reproduction but they tend to die off due to UV light from the sun. In the evening, they are recovering from the high UV light as their reproduction goes up. The main cause of this contamination was as a result of open defecation, infiltration from nearby pit latrines and also unprotected and shared spring by animals and humans. The difference in E-Coli recordings for the morning, afternoon and evening was majorly as a result of temperature and pH differences.

E-coli and Total coliform is not normally distributed and therefore it is not advisable to use the standard arithmetic means as they can be easily skewed by any high bacteriological value recorded. Therefore we use the logarithmic scale.

4.1.5 Total Coliform (CFU/100ml)

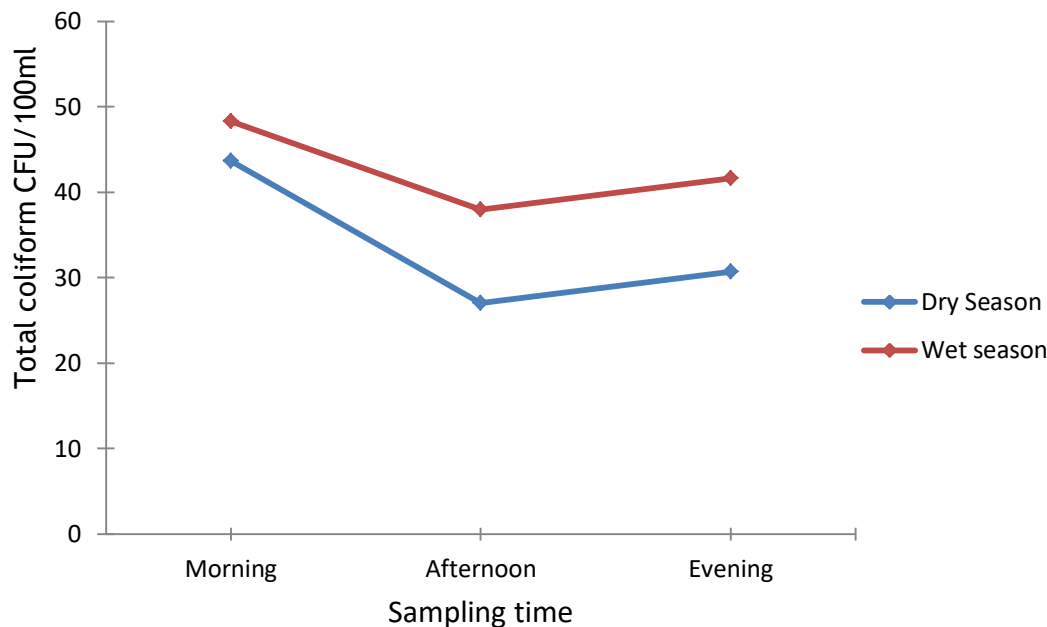

Figure 6: Total coliform variation in both seasons

Total coliform is a collection of relatively harmless micro-organism that live in large numbers in the intestines of humans and other warm and cold blooded animals which aids in food digestion. Presence of total coliform in water indicates presence of water contamination with E-Coli and the source may have been contaminated with pathogens or disease causing bacteria or viruses which also exist in faecal materials.

During the dry season, we did sample collections and sampling at different hours of the day (Morning, Afternoon and evening) and we obtained 43 CFU/100ml, 28 CFU/100ml and 31 CFU/100ml respectively. During the wet seasons, the morning, afternoon and evening sapling gave us a reading of 48 CFU/100ml, 38 CFU/100ml, and

42 CFU/100ml. These excessively exceed the World Health Organization and also the national guidelines of zero coliform count in potable water.

The presence of total coliform in an indicator for fecal matter from war blooded animals and humans. Total coliform in the spring water was as a result of open defecation, leaching from damp sites, infiltration from nearby pit latrine and also unsafe collecting containers for the residents of Kisenyi Cell. The difference in total coliform was as a result of temperature and pH differences during the sampling times of the day.

Relation between E-coli, total coliform and ground water

Ground water is generally cleaner than surface water because it is filtered as it passes through soil and rocks of different types. However, it can become contaminated by micro-organism like E-coli and total coliform most especially when in areas with poor sanitation facilities, shallow wells or unprotected spring.

Total coliform bacteria are commonly found in soil, plants and surface water. Their presence in ground water is an indicator of poor sanitation, intrusion of surface water through cracks in aquifer protection layers (EPA, 2012).

E-coli as a fecal indicator is a specific type of coliform that is from human or animal feces. It's presence in ground water is a strong signal for fecal contamination which is caused by infiltration from latrines, leaking septic tanks and surface runoff carrying faecal matter (Foster & Chilton 2000).

4.1.6 Total iron

Iron is a naturally occurring mineral found in the world and it dissolves in underground water filters through the surrounding rocks. Pure water is tasteless but larger amounts of iron will give an unpleasant metallic taste. Iron is essential for human nutrition and health effects but in excess can also lead to water hardness, fatigue and anemia in humans (Rizk et al., 2017).

During our experimental sampling, the iron in water was recorded as 0.07 ± 0.00 mg/l for all the three sampling times of the sunny days of morning, afternoon and evening and in all the seasons. The spring's continuous flow during all seasons lead to the release of dissolved iron in water and hence making iron concentration constant

4.1.7 Color

Color in water is an important quality parameter for assessing water quality that reflects both the aesthetic and chemical composition. Color is caused by the natural sources and is categorized as true color and apparent color. During the testing and water sampling for the two seasons, it was recorded that color was 0 PtCo indicating that there was no dissolution of minerals in water even though it was recorded above the standard limits during the preliminary sampling. The presence of low oxygen in the underground of the spring also helped in keeping metals like iron stable soluble form which prevented the yellowing and reddish color forming in water hence constant color recording in all seasons.

4.2 Determination of optimum dosage and the active components of solanum incanum L

The leaves of solanum incanum were collected, cleaned using distilled water and soft brush, and oven dried for 24 hours at 60⁰c before grinding into fine powder. The fine powder was then sieved using a 600 micrometer sieve to attain a uniform fine particle powder by eliminating course particles that could cause turbidity in water and also to increase the surface area of contact with the solvent. The active compounds were extracted by measuring 10 grams of *Solanum powder* into 1 liter jar of water.

The mixture was stirred for at least 30 minutes, filtered using Whatman filter paper and funnel and we obtained about 600ml of a filtrate that was available for examination.

4.2.1 Determination of contact time

When it comes to disinfection, its effectiveness depends on the contact time, which can be defined as the period of time during which water is in direct contact with the disinfectant to allow the microbes to be acted upon (WHO, 2017).

This process was done using a constant dosage of 35ml/l of stock solution and samples for E-coli and total coliform taken in time interval of 0, 15, 30, 45, 60, 75, and 90 minutes. This was documented for all aqueous plant extract in microbial disinfection (Suleiman et al., 2020).

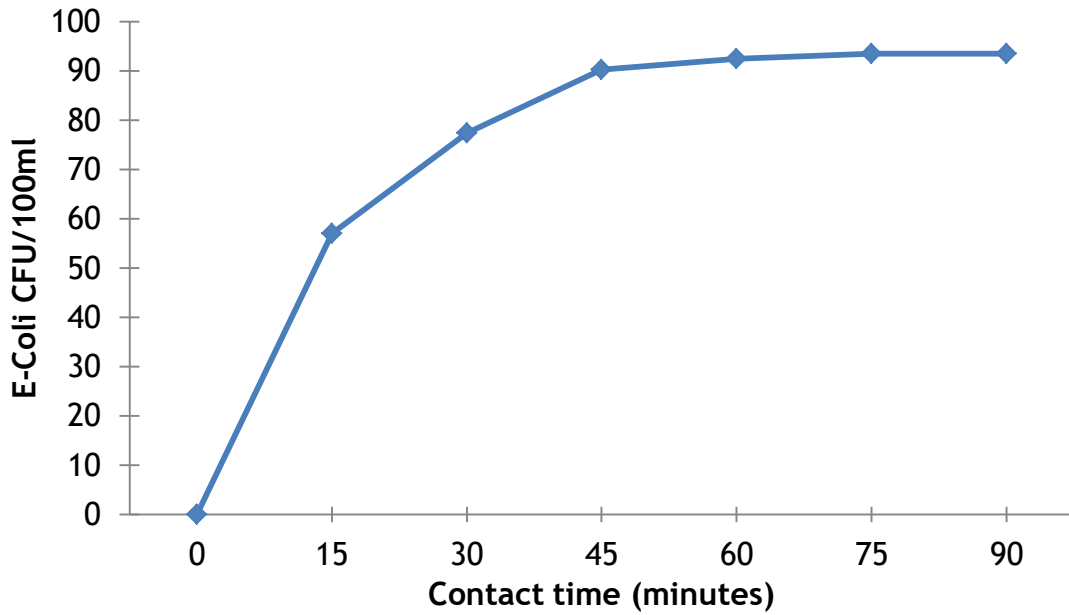

Figure 7: The percentage reduction of E-Coli over contact time

The micro bacteria showed a decrease with increase in contact time using a constant dosage of 30 ml of the stock solution of *solanum incanum* extract. The maximum microbial reduction occurs at 60 minutes and between 45 and 60 minutes, the decrease of the micro-organism is small which suggests that the disinfectant has reached its optimal performance at 45 minutes.

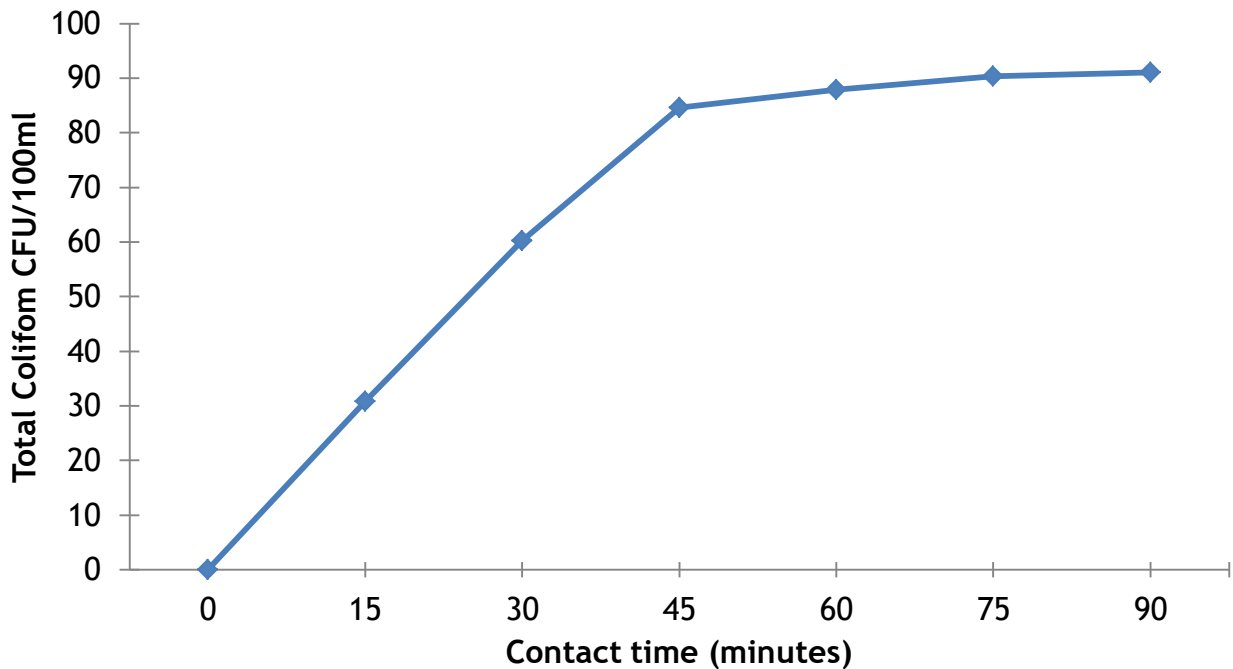

Figure 8: Percentage reduction of total coliform over time

From the graphs, it was discovered that the contact time is 45 minutes since the percentage decrease of micro bacteria was less and the curve was becoming flat as time increases at constant dosage.

The trends of the above graphs were influenced by the presence of photochemical compounds in *solanum incanum* which disrupted the bacterial membrane and the metabolic processes.

The graphs show that the contact time is 45 minutes with the achieving of 90% e-coli percentage reduction. By exceeding 45 minutes, it gives minimal benefits of e-coli reduction from the raw water. These patterns represented on the graphs are typical for natural coagulants and disinfectants.

4.2.2 Determination of optimal dosage

The same amount of water 1000 ml was treated with different amounts of disinfectant in stock solution as shown in the graphs below. The choice for dosage depended on the change of the water chemistry during the trial runs with the disinfectant. The Physiochemical quality of water was observed to be increasing as the dosage was increasing and the bacteriological quality was decreasing.

4.2.2.1 pH

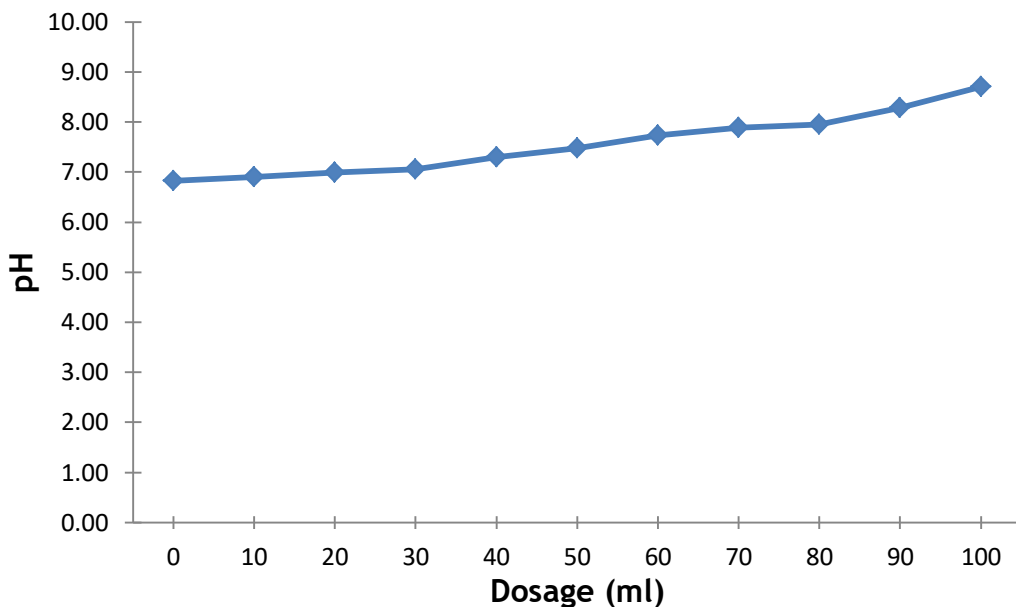

Figure 9: Variation of pH with dosage

The pH of water is steadily increasing with increase in dosage as it is observed from (0-100) ml but still in the range of 6.5-8.5. Small changes are observed between 0 and 30 ml which suggested that there is no significant alteration of the water chemistry at

lower dosage. The natural disinfectant has a slightly alkaline effect in water treatment.

The presence of alkaline compounds like alkaloids, sponins, glycoside and mineral salts and weak bases that neutralizes acidic water by releasing basic ions that raised the pH of raw water from 6.8 - 8.70 at dosage of 0 -100 ml of the natural disinfectant.

4.2.2.2 Color (PtCo)

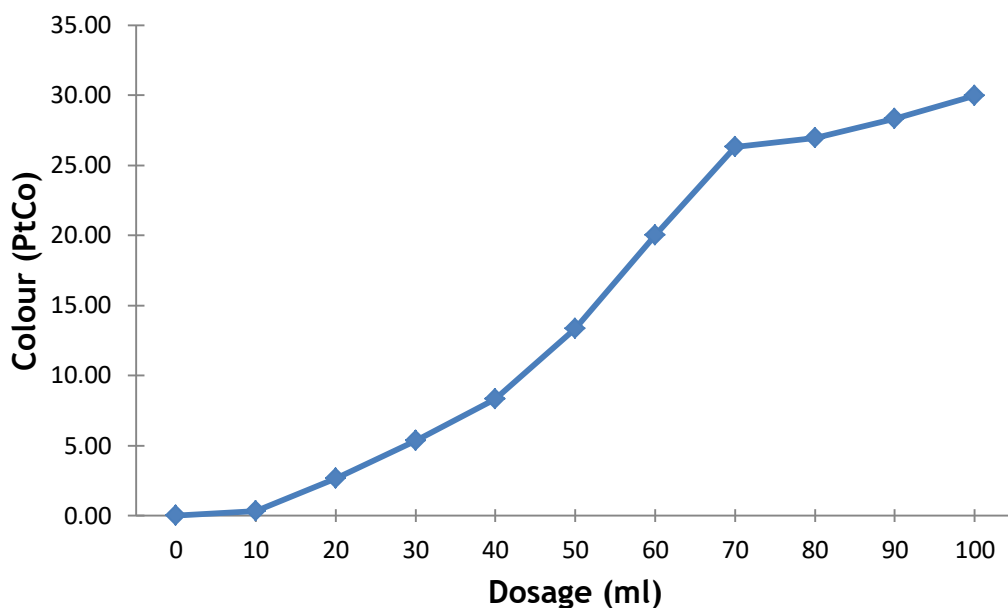

Figure 10: Variation of color with dosage

The apparent color is observed to be increasing from 0 - 29.97 PtCo with the increase in dosage from 0 - 100 ml as seen on the graph which is much higher than the recommended potable water standards of 15 PtCo. This therefore indicated that natural material/ disinfectants introduce more color compounds in water.

The natural disinfectant introduced its pigment such as phenolics, flavonoids, tannins and alkaloids into the water causing the color to rise. Therefore the increase in dissolved matter in water caused the color and turbidity to increase. At low dosage, color did not rise significantly but as we went beyond 50 ml, the line moved sharply upwards.

4.2.2.3 Turbidity (NTU)

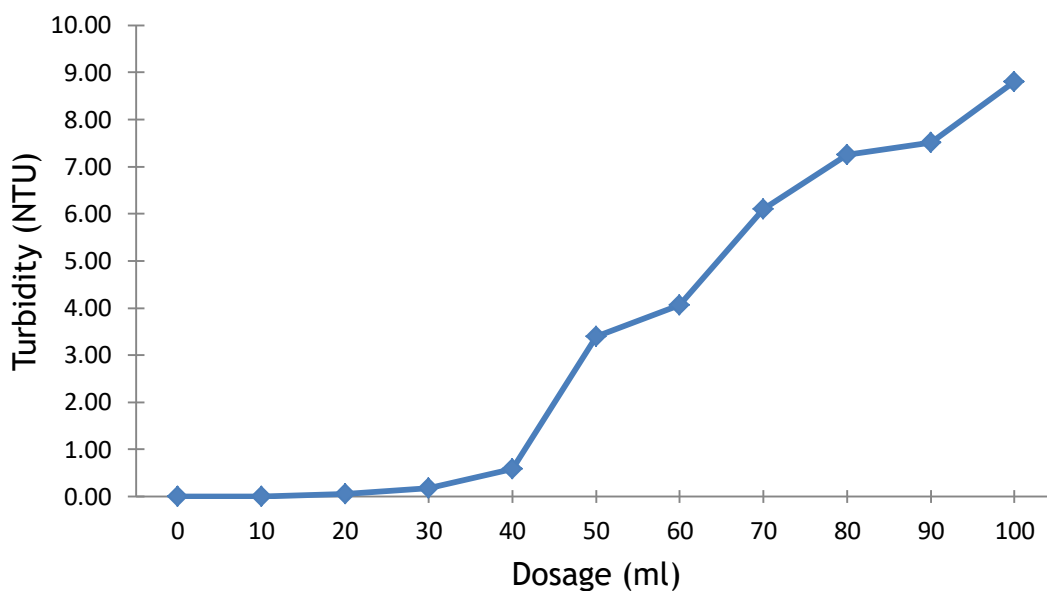

Figure 11: Variation of turbidity with dosage

The turbidity of water increased from 0 NTU to 8.8 NTU which is above the recommended standards for both the national, international and the World Health Organization potable water guidelines of not more than 5 NTU. The natural disinfectant introduced fine plant particles into water, and soluble organic compounds also increased. Therefore the increase in dissolved matter in water caused

the color and turbidity to increase and also the incomplete floc formation during the disinfection increased the turbidity of the water. At low dosage, turbidity did not rise significantly but as we went beyond 40 ml, the line moved sharply upwards.

4.2.2.4 E-Coli CFU/100ml

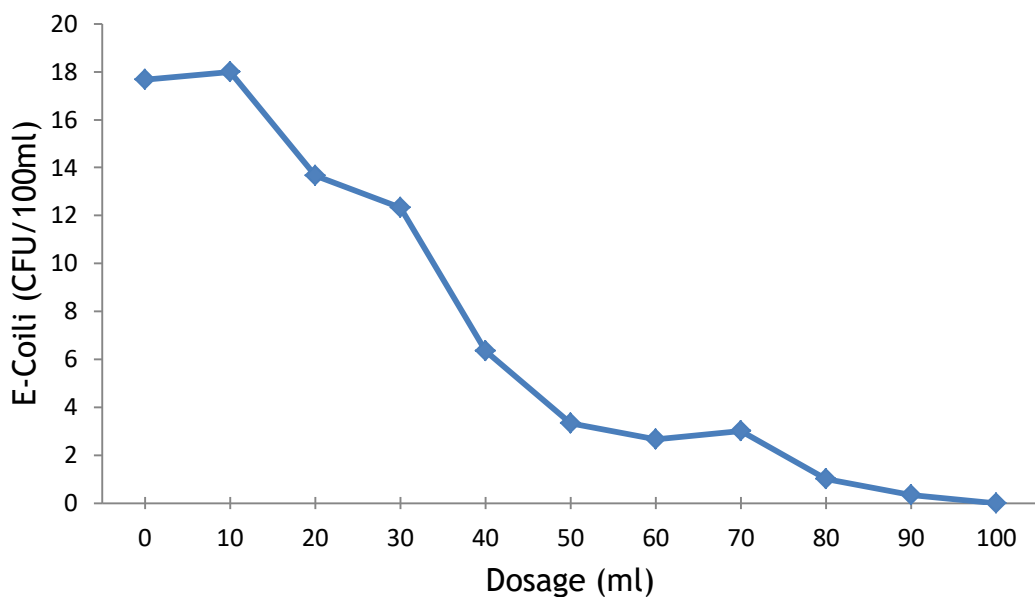

Figure 12: Variation of E-coli reduction with dosage

The E-coli reduced with the increase in dosage as observed on the graph above as E-coli died off completely at 100 ml dosage. The release of the antimicrobial compounds like alkaloids, saponins, tannins and flavonoids from the disinfectant which damaged the cell membrane and interfered with bacterial enzymes that are responsible for metabolic processes and hence making E-coli to decrease in number or die off.

4.2.2.5 Total coliform (CFU/100ml)

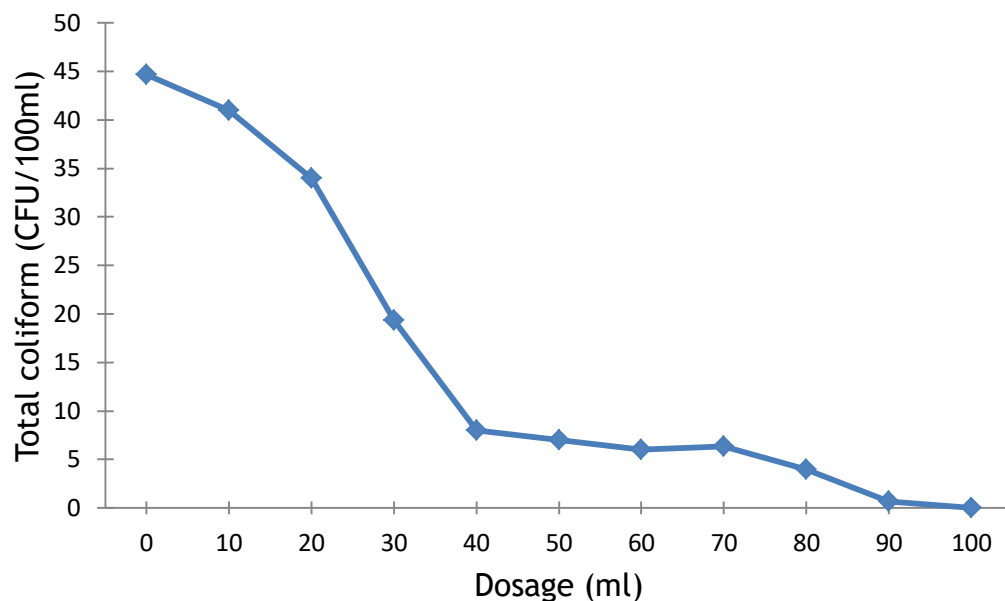

Figure 13: Variation of total Coliform with dosage

Pathogens showed a decrease at higher dosage of 100 ml were they died off 100%. *Solanum incanum* contains the bioactive antimicrobial compounds like the alkaloids, saponins, tannins, flavonoids, phenolic compounds, and glycoalkaloids which are responsible for disrupting cell membrane causing leakage of their contents and this intern leads to the dying off of the E-coli and Total coliform that was present in the water. These bioactive compounds also interfered with the bacterial enzymes which destabilized their metabolic processes making them unable to reproduce and survive during the disinfection processes. There was also an increase in the pH of the water during the disinfection process which in turn reduced their survival rates in the treated water.

After careful observations, the disinfectant even though we achieved complete standards for the disinfectant against E-coli and Total coliform at 100ml/l of water treatment, other parameters like color, turbidity were compromised with the increase in dosage. This therefore led us fixing it to 40 ml/l as our optimum dosage. With the reference from the water supply design manual, the demand of water required by a single household was estimated as 100l or 0.10 m³, the required dosage is 4000ml/100l or 4l/100l or 40ml/1l.

4.3 Designing of a suitable water treatment unit for water treatment at household level

To design a suitable treatment unit, it is necessary to determine the demand of water per household. According to the water supply design manual, the demand of water in the states that are of low income communities like rural and semi urban areas consume 20 l/ca/day (water supply design manual, 2013). Therefore, residents of Kisenyi cell, Namilyango village are categorized under low income communities and their consumption is 20l/ca/day since they are squatters on parish land and railway reserves (water supply design manual, 2013).

A household has an average of 5 members each consuming 20 liters per day M Joseph (personal communication, 6 October 2025).

So; - $5 \times 20 = 100$ liters/day for a single household and add 10% freeboard (prevent overflow and mixing), Volume V becomes 110 liters

Using formula for Volume,

1000 liters = 1 m³, then 110 liters gives us 0.110 m³

$$V = \pi R^2 H \text{ but } V = 0.11 \text{ m}^3$$

We need to estimate the height H of the container and Radius R.

Let the Diameter be 0.4m, making radius 0.2m

$$V = A * H$$

$$H = 0.11 / (\pi * 0.2^2)$$

H = 0.875 m which is approximated to 1 m

Calculating the rates of discharge Q,

Reconfirming Volume $V = \pi r^2 H$,

$$V = \pi * 0.2^2 * 1.0$$

$$V = 0.13 \text{ m}^3$$

Taking velocity as 0.4 m/s for D of 32 diameter pipe (modified haze-Williams formula),

$$Q = A * V$$

$$Q = \pi (0.016)^2 * 0.4$$

Q = 3.217e⁻⁴ m³/s (pipe between the outlet of the disinfection tank and storage tank).

For the outlet tap, consider 15 mm diameter tap with same velocity of 0.4 m/s

$$Q = A \cdot V$$

$$Q = \pi(0.0075)^2 \cdot 0.4$$

$$Q = 7.07e^{-4} \text{ m}^3/\text{s}$$

Limitations of solanum incanum for water treatment

Solanum incanum can help reduce turbidity and pathogens in water but it has limitation especially the inconsistent effectiveness, toxicity concern, poor standardization and limited scope of treatment as they can be seen below;-

- ✓ *Solanum incanum* can add toxicity to water when not properly prepared since it contains alkaloids and solanines which are poisonous.
- ✓ It's more effective in reducing pathogens at higher dosage which in turn increase other qualities like pH, Color and turbidity.
- ✓ Compared to choline, *solanum incanum* requires longer contact time of up to 2 hours.

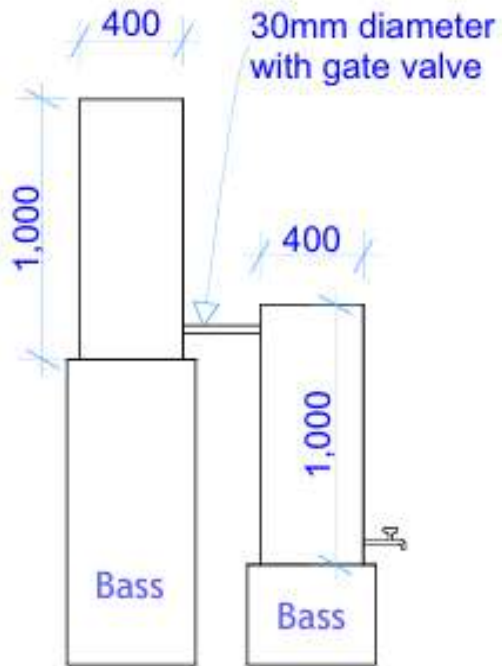

Side Elevation 1:20

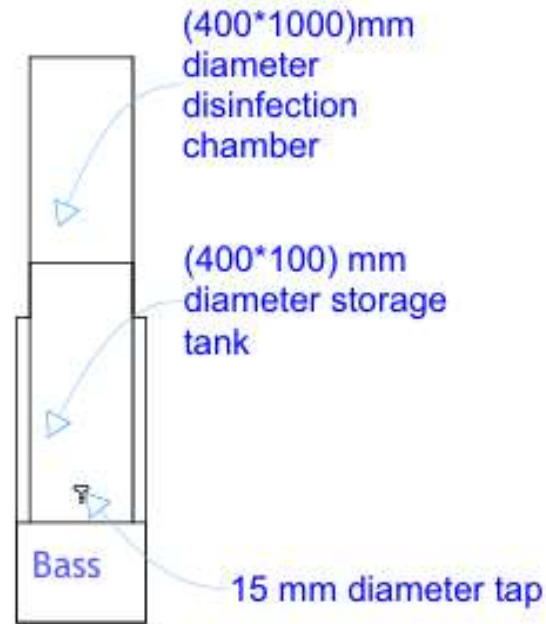

Front Elevation 1:20

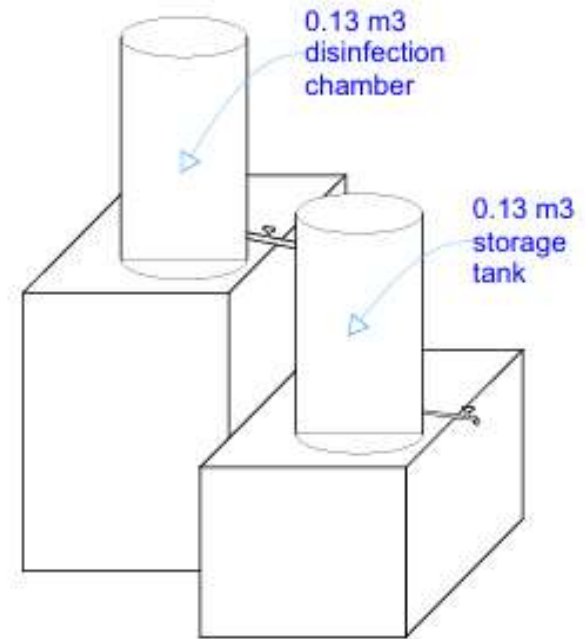

3D Diagram 1:25

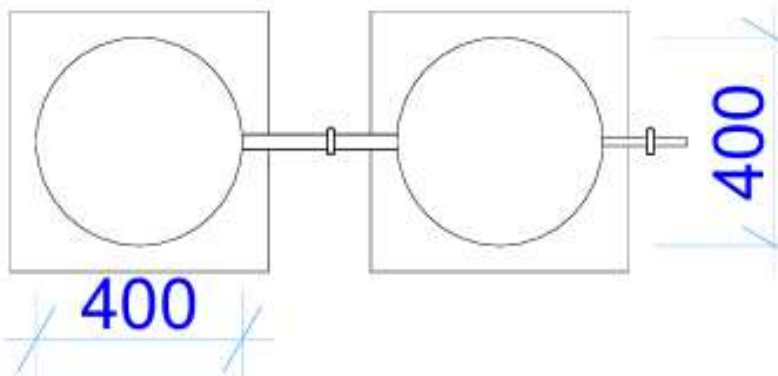

Plan View 1:10

PROJECT:-

THE USE OF SOLANUM INCANUM FOR WATER TREATMENT AT HOUSEHOLD
LEVEL CASE STUDY OF NAKIJEERA SPRING

DROWING NAME:-

PLAN, FRONT AND SIDE ELEVATION, AND 3D

DRAFTED BY:-

WANABADI PETER M22B32/034
BWAMBALE WILBERFORCE M22B32/009

SCALE:- 1:25, 1:20, 1:10

MODIFIED DATE:-

PAPER SIZE:- A3

22/11/2025

CHAPTER FIVE: CONCLUSION AND RECOMMENDATIONS

5.0 CONCLUSION

Assessing the effectiveness of *solanum incanum* in the treatment of water at a household level has been our study for its being readily available making it inexpensive for low income earners, biocompatible and avoiding toxic by-products to the environment. The study was done on Nakyijeera spring in Namirango Village, Kisenyi cell, Mukono District and experiments using *solanum incanum* powder demonstrated significant improvement in the microbiological quality of water, these was achieved with the presence of the bioactive compounds like alkaloids, flavonoids, tannins and saponins which contributed both the coagulation and disinfection of water by destabilization and inactivating the microbial pathogens like E-Coli and Total Coliforms and the following are the conclusions;-

- ✓ The initial water had contamination of E-coli 16 CFU/100ml and total coliform of 48 CFU/100ml which was as a result of open defecation, surface run off into the spring, and infiltration from nearby pit latrines and dump sites.
- ✓ The active components of *solanum incanum* powder were extracted using distilled water, contact time found to be 45 minutes with the optimal dosage of 40 ml which gave an E-coli and Total coliform reduction to 2 CFU/100ml and 5 CFU/100ml respectively.
- ✓ Water treatment design and prototype was made for household level and therefore this study supported the integration of indigenous plant based solution into local water treatment practices so as to achieve the sustainable

development goal (SDG 6) which aims at universal access to safe and affordable drinking water.

5.1 RECOMMENDATIONS

Despite of the challenges, the project was successfully completed in time and below are the recommendations that need to be addressed;-

- ✓ Communities that rely on water from unprotected springs should be sensitized and trained on the safe preparation and controlled use of *solanum incanum* extract for water disinfection and purification at household level in rural and semi urban areas.
- ✓ The Nakyijeera spring should be protected so as to prevent continuous contamination of the spring water.
- ✓ There should be more treatment of water using other methods so as to enhance the bacteriological quality of water.
- ✓ Additional laboratory studies should be focused on refining and detoxifying residual toxic alkaloids while preserving the plant's antimicrobial active components to ensure treated water remains safe for domestic consumption.

CHAPTER SIX: REFERENCES

1. Adomi Mbina, S., Wilson, G., Daniel Eze, E., Pius, T., Robinson, S., Moyosore Afodun, A., & Ezekiel, I. (2020). Contaminants of Domestic Rural Spring Water Sources in Bushenyi-Ishaka Municipality, Western Uganda. *Journal of Health and Environmental Research*, 6(3), 51. <https://doi.org/10.11648/j.jher.20200603.12>
2. Al-Shehri, H. S., Alanazi, H. S., Shaykhayn, A. M., Alharbi, L. S., Alnafaei, W. S., Alorabi, A. Q., Alkorbi, A. S., & Alharthi, F. A. (2022). Adsorption of Methylene Blue by Biosorption on Alkali-Treated *Solanum incanum*: Isotherms, Equilibrium and Mechanism. *Sustainability (Switzerland)*, 14(5). <https://doi.org/10.3390/su14052644>
3. Basavaraju, M., & Gunashree, B. S. (2023). *Escherichia coli* : An Overview of Main Characteristics . *Escherichia Coli - Old and New Insights, November*. <https://doi.org/10.5772/intechopen.105508>
4. Benalia, A., Derbal, K., Amrouci, Z., Baatache, O., Khalfaoui, A., & Pizzi, A. (2024). Application of Plant-Based Coagulants and Their Mechanisms in Water Treatment: A Review. *Journal of Renewable Materials*, 12(4), 667-698. <https://doi.org/10.32604/jrm.2024.048306>
5. Hadadi, A., Imessaoudene, A., Bollinger, J. C., Assadi, A. A., Amrane, A., & Mouni, L. (2022). Comparison of Four Plant-Based Bio-Coagulants Performances against Alum and Ferric Chloride in the Turbidity Improvement of Bentonite Synthetic Water. *Water (Switzerland)*, 14(20). <https://doi.org/10.3390/w14203324>

6. Jan, S., Iram, S., Bashir, O., Shah, S. N., Kamal, M. A., Rahman, S., Kim, J., & Jan, A. T. (2024). Unleashed Treasures of Solanaceae: Mechanistic Insights into Phytochemicals with Therapeutic Potential for Combatting Human Diseases. *Plants*, 13(5). <https://doi.org/10.3390/plants13050724>
7. Karanja, L. N., K'Owino, I. O., Wangila, P. T., & Ramkat, R. C. (2021). Phytochemical Composition and Antibacterial Activity of Fruit Extract of *Solanum incanum* L. against *Ralstonia solanacearum*. *Asian Journal of Applied Chemistry Research*, 9(June), 1-16. <https://doi.org/10.9734/ajacr/2021/v9i430218>
8. Kihampa, C., Mwegoha, W. J. S., Kaseva, M. E., & Marobhe, N. (2011). *Performance of Solanum incunum Linnaeus as natural coagulant and disinfectant for drinking water*. 5(October), 867-872.
9. Koul, B., Bhat, N., Abubakar, M., Mishra, M., & Arukha, A. P. (2022). *Application of Natural Coagulants in Water Treatment* :
10. Lashin, I., Fouda, A., Gobouri, A. A., Azab, E., Mohammedsaleh, Z. M., & Makharita, R. R. (2021). Antimicrobial and in vitro cytotoxic efficacy of biogenic silver nanoparticles (Ag-nps) fabricated by callus extract of *solanum incanum* l. *Biomolecules*, 11(3), 1-22. <https://doi.org/10.3390/biom11030341>
11. Manoharan, R., Nair, C. S., Eissa, N., Cheng, H., Ge, P., Ren, M., & Jaleel, A. (2024). Therapeutic Potential of Solanum Alkaloids with Special Emphasis on Cancer: A Comprehensive Review. *Drug Design, Development and Therapy*, 18(July), 3063-3074. <https://doi.org/10.2147/DDDT.S470925>
12. Mdee, A. L. O. J., & Sadiki, J. W. N. N. (2024). Performance analysis of plant -

- based coagulants in water purification : a review. *Discover Water*.
<https://doi.org/10.1007/s43832-024-00171-0>
13. Moa Megersa, A. B. A. A. B. W. (2014). The use of indigenous plant species for drinking water treatment in developing countries: a review . *Journal of Biodiversity and Environmental Science* , 5(3), 269-281.
<https://doi.org/10.12692/ijb/5.3.269-281>
 14. Mwaura, L., Anjarwalla, P., Ofori, D. A., Stevenson, P. C., Smith, P., & Jamnadass, R. (2015). *Pesticidal plant leaflet : Solanum incanum L. 2*.
 15. Okiishi, M., & Rothmayer, H. (n.d.). *Fundamentals of Fluid Mechanics*.
 16. Onyutha, C., & Auma, N. (2023). Turbidity reduction efficacies of seed kernels of Mango (*Mangifera indica*) genotypes in Uganda. *Heliyon*, 9(11), e21415.
<https://doi.org/10.1016/j.heliyon.2023.e21415>
 17. Pontius, F. W. (2003). Update on USEPA’s drinking water regulations. *Journal / American Water Works Association*, 95(3), 57-68.
<https://doi.org/10.1002/j.1551-8833.2003.tb10314.x>
 18. Rani, A., Singh, J., Pawar, S., Jangra, A., & Kumar, D. (2025). *Solanum incanum L.: an updated review of botany, traditional uses, phytochemistry, and pharmacology. Discover Applied Sciences*, 7(5).
<https://doi.org/10.1007/s42452-025-06646-6>
 19. Republic, T. H. E., & Water, M. O. F. (n.d.). *THE REPUBLIC OF UGANDA MINISTRY OF WATER AND ENVIRONMENT WATER SUPPLY DESIGN MANUAL*.
 20. Rizk, Z. E., El Sharaa, I., & Khadija El-Turki, and S. (2017). Iron determination of drinking water wells in Benghazi City. *Quest Journals Journal of Research in*

Environmental and Earth Science, 3(3), 2348-2532.

21. Sambo, H. S., Olatunde, A., & Kiyawa, A. S. (2016). Phytochemical , Proximate and Mineral Analyses of Solanum Incanum Fruit. *International Journal Of Chemical , Material and Environmental Research*, 3(1), 8-13.
22. Sbhata, D. B., & Abraha, H. B. (2020). Preliminary Antimicrobial Profile of Solanum incanum L.: A Common Medicinal Plant. *Evidence-Based Complementary and Alternative Medicine*, 2020. <https://doi.org/10.1155/2020/3647065>
23. Shahzadi, F., Haydar, S., & Tabraiz, S. (2024). Optimization of Coagulation to Remove Turbidity from Surface Water Using Novel Nature-Based Plant Coagulant and Response Surface Methodology. *Sustainability (Switzerland)* , 16(7). <https://doi.org/10.3390/su16072941>
24. Singh, H. (2024). Water Pollution and Treatment. *Public Health*, May, 172-177. <https://doi.org/10.4324/9781032644257-52>
25. Thorat, R. V., Malvekar, D. A., & Sutar, A. U. (2020). Coagulant potentials of Moringa oleifera seeds in water purification. *Flora and Fauna*, 26(2), 183-189. <https://doi.org/10.33451/floraf fauna.v26i2pp183-189>
26. Waithaka, P. N., Githaiga, B. M., Gathuru, E. M., & Dixon, M. F. (2019). Antibacterial effect of Solanum incanum root extracts on bacteria pathogens isolated from portable water in Egerton University, Kenya. *Journal of Biomedical Sciences*, 6(2), 19-24. <https://doi.org/10.3126/jbs.v6i2.26813>

CHAPTER SEVEN

6.0 APPENDIX



Figure 14: Resident collecting water at the spring



Figure 15: Preparation of stock solution



Figure 16: Preparing of agar



Figure 17: Operating a spectrometer



Figure 18: Stock solution



Figure 19: Solanum powder



Figure 20: Nakyijeera spring



Figure 22: Nakyijeera spring



Figure 21: Sample picking



Figure 23: Sample picking



MINISTRY OF WATER AND ENVIRONMENT
NATIONAL WATER QUALITY REFERENCE LABORATORY - ENTEBBE
Certificate of Analysis



Client Name : Mr Wilberforce and Mr. Wanabadi
 Client Address : Uganda Christian university
 Sample type and Condition : Ground water sample received in Sliire clean sealed Plastic bottle.
 Sample by : Client
 Date Sampled : 14th July 2025
 Analysis Start date : 14th July 2025
 Date received: 14th July 2025
 Analysis Completion date: 17th July 2025

Ref: PM7.8/R-01 E00 NWQRL25 -1384

Certificate No:			
Source Name	Kisenyi Spring		Potable Water Standards (EAS12:2018) Maximum Permissible for Natural Potable Water)
Village	Namiryango		
Parish	Seeta		
Subcounty	Goma		
District	Mukono		
Laboratory Identifier Number	E25/06365		
Parameter	Method Code	Units	Test Results
Color (Apparent)	TM/C-04/01*	PtCo	143.0
Turbidity	TM/C-03/01*	NTU	20.0
pH	TM/C-01/01*	pHunits	6.2
Electrical Conductivity	TM/C-02/01*	µS/cm	68
Total dissolved solids	TM/C-02/02	mg/L	48
Nitrates as N	TM/IO-01/01*	mg/L	1.80
Nitrites as N	TM/IO-01/01*	mg/L	<0.001
Ammonium as N	TM/IO-01/01*	mg/L	0.68
Phosphates as P	TM/IO-01/01*	mg/L	0.03
Total Iron	TM/C-08/01*	mg/L	1.55
Manganese	TM/IO-02/01*	mg/L	0.013
E.Coli	TM/M-01/01*	CFU/100ml	126
Total Coliforms	TM/M-01/01*	CFU/100ml	>400

- Note:
1. This certificate shall not be reproduced, except in full, without the approval of the NWQR Laboratory.
 2. **Test results from sub-contracted Laboratory.
 3. * Accredited Test method.
 4. Analysis site is National Water Quality Reference Laboratory-Entebbe. Environmental conditions are controlled at 20±5°C
 5. The laboratory is managed under ISO/IEC 17025 Laboratory quality management system.

Disclaimer:

- ◆ These results relate to the sample as received and tested. Details of the sample with respect to source and representativeness is the responsibility of the client.
- ◆ Delayed delivery of samples may affect the integrity of the analytical results.
- ◆ This certificate of analysis does not substitute certification of a business or product by the relevant authority.

Reviewed & Authorized by:
 Abraham Otai Samuel; *Abraham Otai Samuel*
 Katumba Godfrey; *Katumba Godfrey*

Issued by

TECHNICAL SIGNATORIES
 NWQRL 17 JUL 2025 NWQRL
 NATIONAL WATER QUALITY REFERENCE LABORATORY-ENTEBBE

PRINCIPAL ANALYST LABORATORIES
 ★ 17 JUL 2025 ★
 NATIONAL WATER QUALITY REFERENCE LABORATORY-ENTEBBE
Sir...

Directorate of Water Resources Management
 Department of Water Quality Management
 Plot 6A-B, Water Works Road, Entebbe
 Waterquality.laboratory@mwre.go.ug
 www.nwqr.mwre.go.ug
 Tel: 0206-905180



UGANDA CHRISTIAN UNIVERSITY

A Centre of Excellence in the Heart of Africa

FACULTY OF ENGINEERING, DESIGN, AND TECHNOLOGY Department of Engineering and Environment

ENVIRONMENTAL QUALITY LABORATORY CERTIFICATE OF ANALYSIS

Certificate Number: EQL2513SE2	
Sample: Water Sample	Sample ID No.: EQL/22/09/0932,1324, 1836
Sample Description: Sald to be "Spring Water"	
Party's Ref No: Nil	Certificate Issue Date: 26 th September 2025
Client Name & Address: 1. Bwambale Wilberforce & Wanabadi Peter	Job Code: Water Quality Test
	Sample Received On: 22 nd September 2025
Physical Address: UCU, Mukono Client's Contact Phone No.: +256 785 195565	Date of Testing: 22 nd September 2025
	Completion Date: 24 th September 2025
Sample Condition:	Liquid sample packed in a 1.5 Ltr plastic bottle

SN	Test Parameter	Units	Test Results			Specification as per EAS-12: 2014	Test Methods
			Morning	Afternoon	Evening		
1	Turbidity	NTU	0.0	0.0	0.0	25	HACH 8195
2	pH value	-	6.7	6.8	6.9	6.5 - 8.5	US ISO 10523
3	E.Coli	CFU/ml	19	17	20	<1	Colilert-18/APHA-9222B
4	Total Coliform	CFU/ml	53	36	40	<1	APHA Method 9222
5	Temperature	°C	19.7	26.4	24.4	N/A	N/A
6	Total iron	Mg/l	0.01	0.01	0.01	0.3	US ISO 6332:1988
7	Color		0	0	0	≤15	HACH 8025

Disclaimer:

- These results relates to the sample as received and tested. Details of the sample with respect to source and representativeness is the responsibility of the client.
- This Certificate of analysis does not substitute certification of a product by the relevant authority.

Remarks: The tested sample is in compliance with physio-chemical characteristics as provided for by the National Standards for Untreated Portable Water. However, biological parameters were all beyond the established standards.

End of Report

Reviewed & Authorized by:

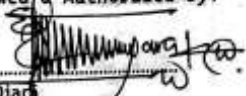
Eddie Ojari
Laboratory Instructor

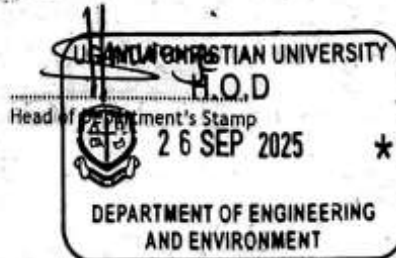



UGANDA CHRISTIAN UNIVERSITY

A Centre of Excellence in the Heart of Africa

FACULTY OF ENGINEERING, DESIGN, AND TECHNOLOGY
Department of Engineering and Environment

ENVIRONMENTAL QUALITY LABORATORY
CERTIFICATE OF ANALYSIS

Certificate Number: EQL2513SE3	
Sample: Water Sample	Sample ID No.: EQL/19/08/0917
Sample Description: Said to be "Spring Water"	
Party's Ref No: Nil	Certificate Issue Date: 26 th September 2025
Client Name & Address: 2. Bwambale Wilberforce & Wanabadi Peter	Job Code: : Water Quality Test
	Sample Received On : 23 rd September 2025
	Date of Testing : 23 rd September 2025
Physical Address: UCU, Mukono	Completion Date : 25 th September 2025
Client's Contact Phone No.: +256 785 195565	
Sample Condition:	Liquid sample packed in a 1.5 Ltr plastic bottle

SN	Test Parameter	Units	Test Results			Specification as per EAS 12: 2014	Test Methods
			Morning	Afternoon	Evening		
1	Turbidity	NTU	0.0	0.0	0.0	25	HACH 8195
2	pH value	-	7.0	6.6	6.7	6.5 - 8.5	US ISO 10523
3	E.Coli	CFU/ml	21	20	22	<1	Colilert-18/APHA-9222B
4	Total Coliform	CFU/ml	40	38	43	<1	APHA Method 9222
5	Temperature	°C	21.7	26.8	24.3	N/A	N/A
6	Total iron	Mg/l	0.01	0.01	0.01	0.3	US ISO 6332:1988
7	Color	PtCo	0	0	0	≤15	HACH 8025

Disclaimer:

- These results relates to the sample as received and tested. Details of the sample with respect to source and representativeness is the responsibility of the client.
- This Certificate of analysis does not substitute certification of a product by the relevant authority.

Remarks: The tested sample is in compliance with physio-chemical characteristics as provided for by the National Standards for Untreated Portable Water. However, biological parameters were all beyond the established standards.

End of Report

Reviewed & Authorized by:

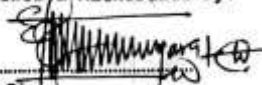
Eddie Ojafa
Laboratory Instructor





UGANDA CHRISTIAN UNIVERSITY

A Centre of Excellence in the Heart of Africa

FACULTY OF ENGINEERING, DESIGN, AND TECHNOLOGY
Department of Engineering and Environment

ENVIRONMENTAL QUALITY LABORATORY
CERTIFICATE OF ANALYSIS

Certificate Number: EQL25135E4	
Sample: Water Sample	Sample ID No.: EQL/02/09/1043
Sample Description: Said to be "Spring Water"	
Party's Ref No: Nil	Certificate Issue Date: 26 th September 2025
Client Name & Address: 3. Bwambale Wilberforce & Wanabadi Peter	Job Code: : Water Quality Test
	Sample Received On : 24 th September 2025
Physical Address: UCU, Mukono Client's Contact Phone No.: +256 785 195565	Date of Testing : 24 th September 2025
	Completion Date : 26 th September 2025
Sample Condition:	Liquid sample packed in a 1.5 Ltr plastic bottle

SN	Test Parameter	Units	Test Results			Specification as per EAS 12: 2014	Test Methods
			Morning	Afternoon	Evening		
1	Turbidity	NTU	0.0	0.0	0.0	25	HACH 8195
2	pH value	-	6.5	6.8	6.9	6.5 - 8.5	US ISO 10523
3	E.Coli	CFU/ml	23	19	22	<1	Collert-18/APHA-9222B
5	Total Coliform	CFU/ml	52	40	42	<1	APHA Method 9222
5	Temperature	°C	22.7	29.1	26.5	N/A	N/A
6	Total iron	Mg/l	0.01	0.01	0.01	0.3	US ISO 6332:1988
7	Color		0	0	0	≤15	HACH 8025

Disclaimer:

- These results relates to the sample as received and tested. Details of the sample with respect to source and representativeness is the responsibility of the client.
- This Certificate of analysis does not substitute certification of a product by the relevant authority.

Remarks: The tested sample is in compliance with physio-chemical characteristics as provided for by the National Standards for Untreated Portable Water. However, biological parameters were all beyond the established standards.

End of Report

Reviewed & Authorized by:

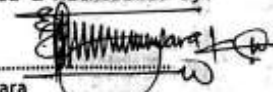
Eddie Ojara
Laboratory Instructor

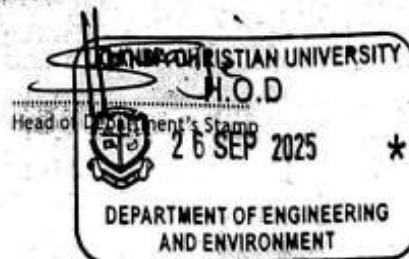



UGANDA CHRISTIAN UNIVERSITY
A Centre of Excellence in the Heart of Africa

FACULTY OF ENGINEERING, DESIGN, AND TECHNOLOGY
Department of Engineering and Environment

ENVIRONMENTAL QUALITY LABORATORY
CERTIFICATE OF ANALYSIS

Certificate Number: EQL2504AU1	
Sample: Water Sample	Sample ID No.: EQL/12/07/1100
Sample Description: Said to be "Spring Water"	
Party's Ref No: Nil	Certificate Issue Date: 3 rd September 2025
Client Name & Address: 1. Bwambale Wilberforce & Wanabadi Peter	Job Code: Water Quality Test
	Sample Received On: 29th August 2025
Physical Address: UCU, Mukono	Date of Testing: 29th August 2025
Client's Contact Phone No.: +256 785 195565	Completion Date: 3 rd September 2025
Sample Condition: Liquid sample packed in a 1.5 Ltr plastic bottle	

SN	Test Parameter	Units	Test Results			Specification as per EAS 12: 2014	Test/Methods
			Morning	Afternoon	Evening		
1	Turbidity	NTU	0.0	0.0	0.0	25	HACH 8195
2	pH value	-	5.4	6.2	5.7	6.5 - 8.5	US ISO 10523
3	E.Coli	Cfu/mg	16	14	15	<1	Collert-18/APHA-9222B
4	Total Coliform	Cfu/mg	48	32	37	<1	APHA Method 9222
5	Temperature	°C	19	23.5	22.1	N/A	N/A
6	Total Iron	Mg/l	0.01	0.01	0.01	0.3	US ISO 6332:1988
7	Color		0	0	0	≤15	HACH 8025

Disclaimer:

- These results relates to the sample as received and tested. Details of the sample with respect to source and representativeness is the responsibility of the client.
- This Certificate of analysis does not substitute certification of a product by the relevant authority.

Remarks: The tested sample is in compliance with physio-chemical characteristics as provided for by the National Standards for Untreated Portable Water. However, biological parameters were all beyond the established standards.

End of Report

Reviewed & Authorized by:

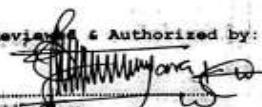
Eddie Ojara
Laboratory Instructor

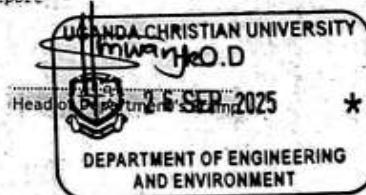



UGANDA CHRISTIAN UNIVERSITY

A Centre of Excellence In the Heart of Africa

FACULTY OF ENGINEERING, DESIGN, AND TECHNOLOGY
Department of Engineering and Environment

ENVIRONMENTAL QUALITY LABORATORY

CERTIFICATE OF ANALYSIS

Certificate Number: EQL2522AU2	
Sample: Water Sample	Sample ID No.: EQL/19/08/0917
Sample Description: Said to be "Spring Water"	
Party's Ref No: Nil	Certificate Issue Date: 4 th August 2025
Client Name & Address: Z. Bwambale Wilberforce & Wanabadi Peter	Job Code: : Water Quality Test
Physical Address: UCU, Mukono	Sample Received On : 3 rd September 2025
Client's Contact Phone No.: +256 785 195565	Date of Testing : 3 rd September 2025
Sample Condition: Liquid sample packed in a 1.5Ltr plastic bottle	Completion Date : 4 th September 2025

SN	Test Parameter	Units	Test Results			Specification as per EAS-12: 2014	Test Methods
			Morning	Afternoon	Evening		
1	Turbidity	NTU	0.0	0.0	0.0	25	HACH 8195
2	pH value	-	6.5	6.6	6.7	6.5 - 8.5	US ISO 10523
3	E.Coli	Cfu/mg	17	11	09	<1	Collert-18/APHA-9222B
4	Total Coliform	Cfu/mg	33	23	27	<1	APHA Method 9222
5	Temperature	°C	22.1	24.8	23.5	N/A	N/A
6	Total iron	Mg/l	0.01	0.01	0.01	0.3	US ISO 6332:1988
7	Color	PtCo	0	0	0	≤15	HACH 8025

Disclaimer:

- These results relates to the sample as received and tested. Details of the sample with respect to source and representativeness is the responsibility of the client.
- This Certificate of analysis does not substitute certification of a product by the relevant authority.

Remarks: The tested sample is in compliance with physio-chemical characteristics as provided for by the National Standards for Untreated Portable Water. However, biological parameters were all beyond the established standards.

End of Report

Reviewed & Authorized by:

Eddie Ojara
Laboratory Instructor

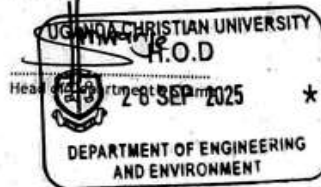



FACULTY OF ENGINEERING, DESIGN, AND TECHNOLOGY
Department of Engineering and Environment
ENVIRONMENTAL QUALITY LABORATORY
CERTIFICATE OF ANALYSIS

Certificate Number: EQL2522AUZ	
Sample: Water Sample	Sample ID No.: EQL/02/09/1043
Sample Description: Said to be "Spring Water"	
Party's Ref No: Nil	Certificate Issue Date: 6 th September 2025
Client Name & Address: 3. Bwambale Wilberforce & Wanabadi-Peter	Job Code: Water Quality Test
	Sample Received On: 4 th September 2025
Physical Address: UCU, Mukono Client's Contact Phone No.: +256 785 195565	Date of Testing: 4 th September 2025
	Completion Date: 6 th September 2025
Sample Condition:	Liquid sample packed in a 1.5 Ltr plastic bottle

SN	Test Parameter	Units	Test Results			Specification as per EAS 12: 2014	Test Methods
			Morning	Afternoon	Evening		
1	Turbidity	NTU	0.0	0.0	0.0	25	HACH 8195
2	pH value	-	6.9	6.9	6.8	6.5 - 8.5	US ISO 10523
3	E.Coll	Cfu/mg	23	17	18	<1	Colilert-18/APHA-9222B
5	Total Coliform	Cfu/mg	50	26	28	<1	APHA Method 9222
5	Temperature	°C	20.7	23.3	21.5	N/A	N/A
6	Total Iron	Mg/l	0.01	0.01	0.01	0.3	US ISO 6332:1988
7	Color	0	0	0	0	≤15	HACH 8025

Disclaimer:

- These results relates to the sample as received and tested. Details of the sample with respect to source and representativeness is the responsibility of the client.
- This Certificate of analysis does not substitute certification of a product by the relevant authority.

Remarks: The tested sample is in compliance with physio-chemical characteristics as provided for by the National Standards for Untreated Portable Water. However, biological parameters were all beyond the established standards.

End of Report

Reviewed & Authorized by:

Eddie Ojara
Laboratory Instructor





NATIONAL WATER AND SEWERAGE CORPORATION
CENTRAL LABORATORY- BUGOLOBI

P.O BOX 7853 KAMPALA Email: waterquality@nws.co.ug

Student: Bwambale Wilberforce M22B32/009 &

Wanabadi Peter M22B32/034

Address: Uganda Christian University

Mukono (Uganda)

Date Sample Tested: 28th November , 2025.

Analysis of Test Results showing contact time determination at a dose of 35ml of the extract (Disinfectant) picked on 28th November 2025.

Experiment 1

s/n	Contact time (minutes)	Microbial reduction CFU/100ml	
		E-coli	Total
1	0	27	48
2	15	12	29
3	30	5	12
4	45	2	4
5	60	1	3
6	75	1	2
7	90	1	1

Remarks: The results for the water samples tested were as above.

Analysed by: Wanyera Julius (QCO) &

Bwambale Wilberforce M22B32/009

Wanabadi Peter M22B32/034





NATIONAL WATER AND SEWERAGE CORPORATION
CENTRAL LABORATORY- BUGOLOBI
P.O BOX 7853 KAMPALA Email: waterquality@nws.co.ug

Student: Bwambale Wilberforce M22B32/009 &

Wanabadi Peter M22B32/034

Address: Uganda Christian University

Mukono (Uganda)

Date Sample Tested: 29th November , 2025.

Analysis of Test Results showing contact time determination at a dose of 35ml of the extract (Disinfectant) picked on 29th November 2025.

Experiment2

s/n	Contact time (minutes)	Microbial reduction CFU/100ml	
		E-coli	Total
1	0	30	63
2	15	18	45
3	30	8	34
4	45	3	12
5	60	3	9
6	75	3	8
7	90	3	8

Remarks: The results for the water samples tested were as above.

Analysed by: Wanyera Julius (OCO) &

Bwambale Wilberforce M22B32/009

Wanabadi Peter M22B32/034





NATIONAL WATER AND SEWERAGE CORPORATION
 CENTRAL LABORATORY- BUGOLOBI
 P.O BOX 7853 KAMPALA Email: waterquality@nwsa.co.ug

Student: Bwambale Wilberforce M22B32/009 &

Wanabadi Peter M22B32/034

Address: Uganda Christian University

Mukono (Uganda)

Date Sample Tested: 04th December, 2025.

Analysis of test results to determine the optimal dose of the extract at contact time (45 minutes) on 04th December, 2025.

RUN 3

SN	Parameter	Units	Applied dosage (ml)										
			0	10	20	30	40	50	60	70	80	90	100
1	Turbidity	NTU	0.00	0.00	0.00	0.20	0.50	4.60	5.20	6.90	8.00	8.02	10.40
2	pH		6.82	6.91	7.01	7.20	7.36	7.36	7.56	7.68	8.00	8.30	8.50
3	Apparent colour	PCu	0.00	0.00	2.00	4.00	7.00	11.00	22.00	30.00	30.90	32.40	35.00
4	E-coli	CFU/100ml	18	20	12	11	8	2	2	3	1	0	0
5	Total coliform	CFU/100ml	44	42	40	36	8	8	6	8	5	0	0

Remarks: The results for the water samples tested were as above.

Analysed by: Wanyera Julius (QCO) &

Bwambale Wilberforce M22B32/009

Wanabadi Peter M22B32/034





NATIONAL WATER AND SEWERAGE CORPORATION
CENTRAL LABORATORY- BUGOLOBI

P.O BOX 7853 KAMPALA Email: waterquality@nwsa.co.ug

Student: Bwambale Wilberforce M22B32/009 &

Wanabadi Peter M22B32/034

Address: Uganda Christian University

Mukono (Uganda)

Date Sample Tested: 03rd December , 2025.

Analysis of test results to determine the optimal dose of the extract at contact time (45 minutes) on 03rd December, 2025.

RUN 1

SN	Parameter	Unit	Applied dosage (ml)										
			0	10	20	30	40	50	60	70	80	90	100
1	Turbidity	NTU	0.00	0.00	0.15	0.20	0.44	2.40	3.40	5.00	6.35	6.40	7.00
2	pH		6.80	6.84	6.92	6.97	7.24	7.52	7.84	8.03	8.23	8.42	8.60
3	Apparent colour	PCu	0.00	0.00	2.00	6.00	10.00	12.00	18.00	24.00	24.90	26.20	26.80
4	E-coli	CFU/100ml	20	16	15	14	8	5	4	3	1	0	0
5	Total coliform	CFU/100ml	44	42	30	10	8	7	5	5	3	0	0

Remarks: The results for the water samples tested were as above.

Analysed by: Wanyera Julius (QCO) &

Bwambale Wilberforce M22B32/009

Wanabadi Peter M22B32/034





NATIONAL WATER AND SEWERAGE CORPORATION
CENTRAL LABORATORY- BUGOLOBI
P.O BOX 7853 KAMPALA Email: waterquality@nwsr.co.ug

Student: Bwambale Wilberforce M22B32/009 &

Wanabadi Peter M22B32/034

Address: Uganda Christian University

Mukono (Uganda)

Date Sample Tested: 20th November , 2025.

Analysis results for the optimal dose (40ml) with contact time of 45 minutes on 20th November, 2025.

SN	Parameter	Unit	Test results	Standard for potable (treated) water
1	Turbidity	NTU	0.5	5
2	pH	-	7.25	6.5 - 8.5
3	Apparent colour	PtCO	8	15
4	E.coli	CFU/100ml	2	0
5	Total Coliforms	CFU/100ml	5	0
6	Total iron	mg/L	0.01	0.30
7	Temperature	°C	23.0	Not specified

Remarks: The results for the water samples tested were as above.

Analysed by: Wanyera Julius (QCO) &
Bwambale Wilberforce M22B32/009
Wanabadi Peter M22B32/034





NATIONAL WATER AND SEWERAGE CORPORATION
CENTRAL LABORATORY- BUGOLOBI

P.O BOX 7853 KAMPALA Email: waterquality@nwscc.co.ug

Student: Bwambale Wilberforce M22B32/009 &

Wanabadi Peter M22B32/034

Address: Uganda Christian University

Mukono (Uganda)

Date Sample Tested: 20th November , 2025.

Analysis results for the optimal dose (0.5mg/L) with contact time of 30 minutes on 20th November, 2025.

SN	Parameter	Unit	Test results	Standard for potable (treated) water
1	Turbidity	NTU	0	5
2	pH	-	6.36	6.5 - 8.5
3	Apparent colour	PtCO	0	15
4	E.coli	CFU/100ml	0	0
5	Total Coliforms	CFU/100ml	0	0
6	Total iron	mg/L	0.00	0.30
7	Temperature	°C	20.6	Not specified

Remarks: The results for the water samples tested were as above.

Analysed by: Wanyera Julius (QCO) &

Bwambale Wilberforce M22B32/009

Wanabadi Peter M22B32/034

