

**A COMPARATIVE STUDY BETWEEN THE CONVENTIONAL METHOD AND
THE USE OF POWDERED ACTIVATED CARBON IN IRON REDUCTION FROM
GROUNDWATER**

ANDREW MBABAALI

S20B32/261

**A FINAL YEAR RESEARCH AND DESIGN PROJECT REPORT SUBMITTED TO
THE FACULTY OF ENGINEERING, DESIGN AND TECHNOLOGY, IN PARTIAL
FULFILLMENT OF THE REQUIREMENTS FOR THE AWARD OF A DEGREE
OF BACHELOR OF SCIENCE IN CIVIL AND ENVIRONMENTAL ENGINEERING
OF UGANDA CHRISTIAN UNIVERSITY**

April, 2024



**UGANDA CHRISTIAN
UNIVERSITY**

A Centre of Excellence in the Heart of Africa

ABSTRACT

This report was specifically looking at the comparison between the conventional treatment method (aeration followed by settling and filtration) and the use of Powdered Activated Carbon (PAC) in an adsorbent filter in total iron reduction from groundwater sources. The PAC was prepared from sawdust.

The water sample was collected from iron contaminated ground water source (borehole with hand pump). Both treatment methods indicated above (conventional and adsorption) were applied to check the total iron reduction from the ground water source and the results were compared in order to determine which method could be more effective in total iron reduction.

Total iron levels were tested both before and after the treatment and the results showed that the conventional method was able to reduce the total iron concentration by 95.22% (from 41.44mg/L to 1.98mg/L) while on the other hand, PAC layer thicknesses of 2.5cm, 5cm, and 7.5cm were able to reduce the total iron concentration by 99.08%, 99.20%, and 99.40% respectively between 41.44mg/L and 0.38mg/L, 41.44mg/L and 0.33mg/L and 41.44mg/L and 0.25mg/L respectively . However, the reduced iron levels to (1.98mg/L and 0.33mg/L for conventional and PAC respectively) were still above the permissible limits compared to the Uganda National Standards for treated potable water which is 0.3mg/L.

But since 0.33mg/L total iron is also within the permissible limit of the Uganda National Standards for untreated potable water (1mg/L), it was considered to be safe at household level.

DECLARATION

I, **Andrew Mbabaali** hereby declare that this is my original work, is not plagiarized and hasnot been submitted to any other institution for any award.

Student Signature: Date:

APPROVAL.

This report has been read through clearly and approved by my academic supervisor.

Name:

Supervisor Signature: Date:

DEDICATION

I dedicate this report to all parents and family especially who have supported me morally, spiritually and financially. They have been pillars through this period and their encouragement gave me the fuel to keep going strong. Thank you for all and may the Good Lord bless you abundantly.

ACKNOWLEDGEMENTS

First of all, I want to thank the Almighty God for his protection through all the final year research and design project. I am also grateful to our academic supervisor Eng. Prof. Eleanor Wozei for her tireless guidance through the research period not forgetting the department of engineering and environment for allowing us carry out some of the Laboratory tests and analyses in the University Environmental Quality Laboratory. I as well appreciate the support from the staff of Bio Core Enterprises Laboratory for their guidance in the sample collection and preservation processes. May God reward and bless you all.

LIST OF TABLES

Table 1: Physicochemical characteristics of the raw water.	18
Table 2: Percent reduction of each treatment method.....	19
Table 3: Data used in determining the most effective PAC thickness	19
Table 4: T-values for the different paired samples.....	23
Table 5: Performance of PAC	25

LIST OF FIGURES

Figure 1: Total Iron reduction.....	26
Figure 2: Electrical Conductivity for the different water samples	27
Figure 3: Total Iron Concentrations against PAC depth	28

LIST OF APPENDICES

APPENDIX A: MATERIAL PREPARATION 39

APPENDIX B: FIELD VISIT 40

APPENDIX C: LABORATORY ACTIVITIES..... 41

APPENDIX D: DRAWINGS..... 42

APPENDIX E: CERTIFIED LAB REPORTS..... 44

LIST ACRONYMS AND ABBREVIATIONS

DO: Dissolved Oxygen

e.g.: For example.

cm: Centimeter

EC: Electrical conductivity

EPA: Environmental Protection Agency

Exp: Experiment

HDPE: High Density Polyethylene

ISO: International Standardization Organization.

MWE: Ministry of Water and Environment

PAC: powdered activated carbon

UNS: Uganda National Standards

US: United States

WHO: World Health Organization

WSDM: Water Supply Design Manual

WTPD: Water Treatment Plant Design

CONTENTS

ABSTRACT	i
DECLARATION	ii
APPROVAL.....	iii
DEDICATION.....	iv
ACKNOWLEDGEMENTS	v
LIST OF TABLES	vi
LIST OF FIGURES	vii
LIST OF APPENDICES	viii
LIST ACRONYMS AND ABBREVIATIONS.....	ix
CHAPTER 1: INTRODUCTION	1
1.1 Background.....	2
1.2 Problem statement	3
1.3 Main objective.....	4
1.4 Specific objectives	4
1.5 Research questions.....	4
1.6 Geographical scope of the study	5
1.7 Justification	5
1.8 Significance	6
CHAPTER 2: LITERATURE REVIEW	7
2.0 Introduction.....	7
2.1 Mechanism of adsorption	7
2.2 Iron Contamination	8
2.3 Powdered Activated Carbon	9
2.4 The Conventional method of Iron removal.....	9
2.5 Adsorption of inorganics and ionic compound	10
CHAPTER 3: METHODOLOGY.....	11
3.1 Sample collection and preservation.....	11
3.2 Material preparation	11
3.3 To determine the physicochemical characteristics of the water.....	13
3.4 To evaluate the iron reduction between the two methods	15
3.5 To determine the adsorbent filter unit with the best performance to be	

implemented for iron reduction at household levels	16
CHAPTER 4. RESULTS AND DISCUSSION	18
4.3 Determining the most effective PAC thickness	19
3.4 SYSTEM DESIGN (Lab scale)	32
CHAPTER 5. CONCLUSIONS AND RECOMMENDATIONS	37
5.1 Conclusions	37
5.2 Recommendations	38
APPENDICES	39
References	51

CHAPTER 1: INTRODUCTION

Uganda is one of the countries in the world that suffer iron contamination in ground water (Ministry of Water and Environment 2020) which particularly proved Rakai district for having this issue. High levels of iron in drinking water can cause adverse health effects, such as anemia, skin discoloration, and liver damage (Abdelhafeez et al., 2020). Therefore, several methods have been developed to remove iron from groundwater, including aeration and chemical precipitation followed by sedimentation, ion exchange, and adsorption (Kasprzyk-Hordern et al., 2018). The conventional method used is aeration where the water is exposed to air or oxygen to facilitate the oxidation of soluble ferrous iron to insoluble ferric iron that is then settled or filtered out (Wang, 2020).

Activated carbon is a porous material that has a high surface area, making it a good adsorbent for a wide range of contaminants, including iron (Suryawanshi, 2020).

When the activated carbon is finely ground to a powder form, it is referred to as powdered activated carbon (PAC). PAC has gained recognition as a promising solution for the removal of iron from water due to its exceptional adsorption capacity, ease of application, and cost-effectiveness (Baharudin, 2021).

The removal of iron from water by PAC primarily involves the adsorption of iron ions onto the carbon surface and the adsorption occurs through physical and chemical interactions, with the porous structure of PAC providing ample sites for iron ions to adhere (Aprianti et al, 2022).

1.1 Background

The rural population in Uganda mostly depend on ground water sources like well water, spring water and hand pumped water systems as their primary source of water. Therefore, ground water provides up to 71% of clean water for Uganda's rural population (O'Hanlon, 2021).

Drinking water should be clean and safe for the human welfare (Srivastava, 2020). Groundwater contamination has had a major complication on the environment and human life that utilizes (Al-Taai, 2021). One of the major contaminants in groundwater is iron which may result in red-brown staining of bathroom fixtures, laundry and utensils (Brindha, 2020).

In the ground, Iron usually occurs in the soluble state. Once groundwater containing iron is exposed to dissolved oxygen under conditions with a pH range of 5.5-9.5, it oxidizes to insoluble state which is reddish-brown and stains domestic ware (Beek, 2020). Iron is a metal that exists naturally in the earth's crust (Şenol, 2023). In water iron originates from weathering of rocks rich in iron such as pyrite and is induced in groundwater as divalent ferrous iron Fe^{2+} (soluble form) (Usman, 2020). Therefore, the origin of iron in groundwater depends on the geological nature of the soil (Zhang, 2020). The maximum acceptable concentration of Iron in water should not exceed 0.3mg/L (WHO, 2011).

Activated carbon is a form of carbon that has been treated chemically with an acid and then heated at extreme temperatures to make it highly porous and increase its surface area. Powdered activated carbon is a fine powder form of activated carbon (Bahri, 2020). Powdered activated carbon has a high adsorption capacity for organic

and inorganic compounds, making it a widely used material for water and air treatment (Azad, 2021). Sawdust however has a high carbon grade and after chemical activation, it is highly feasible for use as an adsorption material. (Popovici, 2021)

Therefore, this research is aimed at carrying out a comparative study of the conventional method used, Aeration with sedimentation, versus the use of powdered activated carbon from sawdust as an adsorbent in the removal of Iron from groundwater. Establishing the iron reduction from water using each method and comparing the associated costs will give insight on what method can be recommended for small-scale treatment.

1.2 Problem statement

Rakai District in Uganda has high levels of iron in ground water sources. This was caused by the underlying nature of ground rocks that have high Iron contents and end up contaminating the groundwater (Guma, 2021). This has made it hard to utilize this abundant water source. Iron has adverse effects of pigmentation of hair, skin, and clothes, alters the taste of water and food, causes significant damage to pipes through clogging (Adarsh, 2023), and causes nausea, and abdominal pain, among others (Stephanie, 2018) to people when consumed in excess. High iron may also affect water supply infrastructure; 55% of hand-pump and borehole facilities by WaterAid Uganda in Amuria and Katakwi districts in northern Uganda failed due to high contents of Iron in groundwater, causing people to lack access to safe and clean water (UGPro, 2020). Iron in well water can be removed using sequestration methodology that involves chlorination, oxidation, and UV filtration. This method is expensive, and the chlorine leaves an unpleasant taste in the water (Seymour et al, 2020). Alternative methods of

removing Iron from the water have been explored by (Wang et al, 2019) such as the use of powdered activated carbon from sawdust to adsorb any substances such as Iron from the groundwater.

1.3 Main objective

The main objective of this study was to conduct a comparative study between the conventional method of iron reduction using aeration and sedimentation, and the utilization of powdered activated carbon (PAC) from sawdust in an adsorbent filter in the removal of iron from groundwater.

1.4 Specific objectives

The specific objectives were

1. To determine the physicochemical characteristics (pH, DO, EC, temperature and total iron content) of the raw water from selected boreholes in the study area
2. To evaluate the iron and compare the iron reduction by the two methods under time constraints and compare the treated water quality with Uganda treated potable water standards
3. To determine the adsorbent filter unit with the best performance to be used for iron reduction at the household levels

1.5 Research questions

The study was guided by the following research questions.

1. How can the physicochemical characteristics of the raw water be determined?
2. How can the Iron be evaluated in order to compare the Iron reduction by each

of the two methods such that they can further be compared with the Uganda treated potable water standards?

3. How can the adsorbent filter unit with the best performance be determined to be used for iron reduction at the household levels?

1.6 Geographical scope of the study

The scope of the study was Rakai District, Kyotera County, Kooki Sub-county, Lwanda Parish, Kanoni Village in central Uganda.

1.7 Justification

The presence of functional groups such as Hydroxyl (-OH), Carbonyl (C=O), Carboxyl (-COOH), and many others that are found on the carbon surfaces enhance chemical interactions making PAC an efficient iron adsorbent whereby Iron ions are attracted to the carbon surface due to electrostatic forces and they form complexes with organic matter further improving their reduction. (Murugan, 2020)

Activated carbon is better suited to the removal of organic substances such as volatile organic compounds, chlorine, chloramines, taste, odor, among others (Kibami, 2022). However, the use of chemical activation is another alternative as it has made it possible to remove inorganic substances from the water (Srivastava, 2021). The use of substances such as acids like sulphuric acid and phosphoric acid during the impregnation process before heating the carbon at extreme temperatures with optimal conditions of 600°C for 60 minutes with an impregnation ratio of 2:1 modifies the structure of the activated carbon making it adaptable to the removal of inorganic substances from water (Kumar, 2022). Acid activation creates surface functional groups, like phosphate groups

(PO_3H_2) introduced onto the carbon's surface. These functional groups can chemically interact with inorganic ions in the water, promoting adsorption (Rey-Raap, 2020).

Sawdust's carbon content ranges from 77.51% to 93.59%, and ash content as low as 0.08% (Elehinafe et al, 2019). The powdered activated carbon contains large carbon grade and porosity that makes the carbon materials possess larger particle size or a coarser structure compared to other grades and presence of pores or empty spaces within its material which makes it a high surface area adsorbent with a large amorphous structure which has made it a suitable material for adsorption (Heidarinejad, 2020).

1.8 Significance

There is an improved water quality for the users as the Iron in water can impart an unpleasant taste and odor, and can also cause staining of clothes, sinks, and other surfaces. By removing iron from water using activated carbon, the water quality is improved, making it more aesthetically pleasing and usable for household purposes.

There are health benefits because high levels of iron in drinking water can be harmful to human health, especially in people who suffer from hemochromatosis, (a genetic disorder that causes the body to absorb too much iron). By removing iron from water, activated carbon can help reduce the risk of iron toxicity and associated health problems.

CHAPTER 2: LITERATURE REVIEW

2.0 Introduction

This chapter is emphasizing the critical analysis of what other researchers and scholars say about the topic of this study and the research questions in the previous chapter. It aims to provide a comprehensive understanding of the current state of knowledge and establish the significance of this study.

2.1 Mechanism of adsorption

When a gas or solution is brought into contact with a solid, part of it is taken up by the solid. The molecules disappear from the gas or solution and get attached to the surface (termed adsorption). (Mukhtar, 2020).

The solid that takes up the molecule is called adsorbent, and the gas, vapor or solute taken up on the surface is called adsorbate. Many organic and inorganic contaminants are removed from either gaseous or liquid solutions by adsorption on the very porous medium (solid phase) with large internal surfaces. Therefore, adsorption occurs in two ways as explained below.

- Physisorption (physical adsorption). In this adsorption process, there is a weak van der Waals attraction of the adsorbates to the surface and during the process of physisorption, the chemical identity of the adsorbate remains intact.
- Chemisorption (chemical adsorption). This is where the adsorbates stick to the solid by the formation of a chemical bond with the surface of the solid. This interaction is much stronger than physisorption and in general, chemisorption has more stringent requirements for the compatibility of adsorbate and surface than physisorption.

The steps of adsorption can be summarized as, solute diffusing near the solid surfaces and in the pores of the solid, then the pore walls adsorbing them to wall surface. However, adsorption of dissolved contaminants is a complex phenomenon caused by several mechanisms including London- van der Waals forces, Coulomb forces, hydrogen bonding, ligand exchange, chemisorption, dipole- dipole forces, and hydrophobic forces. For example, hydrocarbons most commonly exhibit adsorption through the process of hydrophobic bonding. Thus, adsorbents are characterized first by surface properties such as surface area, pore size distribution of micropores and polarity. (Zhang, 2020)

2.2 Iron Contamination

Iron is naturally present in the Earth's crust, and groundwater can dissolve iron from geological deposits as it flows through rocks and soil containing iron minerals. (Scholten, 2019)

The World Health Organization sets the guideline for the maximum iron content in drinking water at 0.3 mg/L (WHO 2006).

Iron poisoning has adverse effect on human health hence, immediate action should be taken to treatment it. (Durmuş, 2020)

Excessive iron makes water unpalatable and thus results in the abandonment of the affected source including boreholes and the return to traditional, unprotected sources. These traditional sources are usually small springs that are dammed to form small pools which are highly susceptible to contamination and create potential breeding grounds for mosquitoes.

2.3 Powdered Activated Carbon

Powdered activated carbon (PAC) is a highly porous form of carbon that has been treated with oxygen to increase its surface area and make it more effective at adsorbing contaminants from water. PAC is commonly used in water treatment to remove a variety of contaminants including organic compounds, pesticides, and heavy metals (Khader, 2021).

PAC has been found to be effective at removing a wide range of contaminants from water for example, PAC has been used to remove pesticides such as atrazine and simazine from drinking water (Sundaram et al., 2009). PAC has also been found to be effective at removing heavy metals such as lead, cadmium, and chromium from water (Akhbarizadeh et al., 2013).

2.4 The Conventional method of Iron removal

This method typically involves several steps to effectively eliminate or reduce the presence of iron which include

1. **Aeration/ Oxidation:** Aeration exposes the water to air by allowing the water to come into contact with air, dissolved iron is oxidized from its soluble ferrous state (Fe^{2+}) to the insoluble ferric state (Fe^{3+}). This transformation helps convert the iron into a solid form that can settle at the bottom and be filtered out more easily. (Niu et al., 2021) However, where aeration alone is insufficient for oxidation, chemical oxidants like chlorine, potassium permanganate, or hydrogen peroxide may be added to facilitate the conversion of soluble iron to its insoluble form. This aids in the formation of larger particles that can settle

at the bottom and can be filtered out more effectively.

2. **Settling/ Sedimentation:** After oxidation/ aeration, the insoluble ferric iron is forced to settle at the bottom due to gravity which can then be filtered out.
3. **Filtration:** After aeration, the water passes through a filter media, such as sand, manganese dioxide, or other specialized filter materials. (Reis et al., 2020)
These filters trap the oxidized iron particles, removing them from the water. However, aeration, settling and rapid sand filtration are the processes involved in traditional way of iron removal from ground water. (Beek, 2020)

2.5 Adsorption of inorganics and ionic compounds

A great number of studies have been conducted on chloride and sulfate solutions of iron. Activated carbon displays very strong reduction properties, converting ferric salts to the ferrous condition in the absence of air (Xu et al, 2019). When an abundance of dissolved oxygen is present, activated carbon will act as a catalyst for the oxidation of ferrous iron to ferric iron, which is easily precipitated at pHs over 5 (Xiao et al, 2020). Therefore, both ferrous chloride and ferrous sulfate are adsorbed to some extent but not sufficiently to compete economically with precipitation methods presently used in the water field.

CHAPTER 3: METHODOLOGY

3.1 Sample collection and preservation

Pump sampling was undertaken by lowering a pump into the borehole to extract water. Water was pumped from the boreholes for about 25 minutes before the sample was collected. (University, 2020). This was because the casing material of the borehole was not known and also to eliminate the factor of iron contamination from the borehole casing. (Hanna Andersson, 2002).

The sample was then collected in 5L plastic containers of HDPE material with HDPE screw cap. This was because HDPE has very good compatibility rating with most chemicals and is resistant to strong acids and bases, as well as gentle oxidants and reducing agents (CPLabSafety, 2023). This was very relevant as the samples were treated with nitric acid to prevent the precipitation of Iron from the sample before laboratory analysis.

Sample preservation

3mL/L of 1M Nitric acid was added to the borehole water sample in order to stabilize the pH of the water such that the iron did not precipitate out before the laboratory analyses. Therefore, with the nitric acid, the iron would not react when collected in the sampling containers as the pH was reduced making any metal present in the sample inert. (Underhill, 2019).

3.2 Material preparation

1. Sawdust carbonization

Sawdust was obtained from a woodworking shop in Mukono town which is located along Mukono-Kayunga Road (100m from Mukono main junction). Hence, the sawdust carbon

was prepared according to the method described as below (Hao et al, 2021).

The sawdust was washed with clean water to remove any impurities present and then sun dried for two days until the water and moisture from it was removed totally.

The saw dust was carbonized in a brick furnace at temperatures of 600°C for 75 minutes.

The carbon was then cooled at room temperature to make it ready for the activation.

2. Carbon Activation process

300g of sawdust carbon was impregnated with 1L of 0.5M phosphoric acid solution, the mixture was thoroughly stirred till it became a thick slurry substance. The slurry mixture was then stored at room temperature for 24 hours in order to allow the acid to penetrate through the pores of the carbon. (Evans, J.,2020) The slurry was placed in an oven and heated to 200°C for 12 hours. It was then cooled at room temperature and thereafter, washed with distilled water to drain away the acid used for activation, oven dried at 110°C for 8 hours, it was then cooled at room temperature and thereafter, crushed by a mortar and pestle to obtain the finer particles. The particles were further sieved through a 300 µm sieve and the particles retained on a 75 µm sieve were considered as the powdered activated carbon (Song, Y., 2022).

3 Sand filter preparation

Sand was obtained from a sand mining site in Nabuti (which is a village in Central Division, Mukono Municipality, Central Uganda). The sand was then washed with clean water until clear water from it was observed. The sand was sun dried for about 2 days in order to remove the moisture content from it. Fine sand and coarse sand portions were obtained by sieving. Coarse sand of 2 mm to 5 mm and fine sand of 0.15mm to 2

mm were used. The gravel to be used was thoroughly washed with clean water to eliminate dust and then sun dried for about 2 days, after which gravel of size 6 mm to 15 mm was obtained by sieving. The model filter layers were arranged with the gravel at the bottom, followed by coarse sand, then fine sand, and PAC at the top. The gravel and sand layers had a constant thickness (5 cm) while the PAC had varying layer thickness (2.5 cm, 5 cm and 7.5 cm) for different filter run experiments (Mesquita, 2019).

3.3 To determine the physicochemical characteristics of the water.

The following are the water quality parameters that were determined;

Dissolved Oxygen, Iron content, Electrical Conductivity, temperature, and pH

pH measurement

A pH meter (Brand/Make: Hanna Instruments, Model Name/Number: HI98103 Checker pH Tester, and Accuracy: ± 0.2 pH unit) was used. This is a scientific instrument used to measure the acidity and alkalinity of liquids. It consists of a probe (a glass electrode that contains a reference and sensitive electrode) and a meter (which display the pH values been measured by the probe)

Steps taken during the test.

The probe was cleaned with distilled water and dried with clean and soft cloth by rubbing it against.

The pH meter was calibrated using a buffer solution (calibration solution with a known pH value of 7). (This was done for 3 times to ensure accuracy) as in the manufacturer's instructions for calibration.

The water sample was poured into a clean and dry container.

The pH probe was immersed into the sample and the sample was stirred with it gently for about 30 seconds to ensure consistent reading.

The stirring was stopped while maintaining the probe immersed in the sample until a stable reading was obtained from the meter.

The reading was then recorded and the probe was cleaned with distilled water for the next test.

Dissolved oxygen (DO) measurement

A Portable Dissolved Oxygen meter (Brand/Make: Palintest, Model Name/Number: Micro 600 Portable Dissolved Oxygen Meter, Accuracy: ± 0.1 mg/L or $\pm 2\%$ of reading, whichever is greater) was used.

This is a device used to measure the amount of oxygen dissolved in a liquid sample. This consists of a probe or sensor to analyze the dissolved oxygen content and a hand-held device that displays the oxygen content in the liquid.

Steps taken

The meter was powered on with fresh batteries in order to avoid power disruptions and it was allowed to warm up for about 3 minutes before use.

The probe cap was removed and the probe was rinsed with distilled water to remove any debris or contaminant.

The meter was calibrated following the manufacturer's instruction using the calibration solution.

The probe was carefully inserted into the water sample as it was fully immersed in the water without touching the bottom and the sides of the container.

The meter was allowed to stabilize and the readings displayed were noted.

Electrical conductivity (EC) and Temperature measurement

A conductivity meter (Brand/Make: Wagtech International, Model Name: Wagtech Potatech EC, Accuracy: Typically, $\pm 2\%$ of full scale) was used which measured both EC and temperature.

Steps taken

The conductivity meter was first calibrated according to the manufacturer's instructions (calibration typically involved using distilled water of a known conductivity of $0 \mu\text{S}/\text{cm}$).

The representative water samples were collected in clean containers.

The conductivity meter was turned on and allowed to stabilize for 5 minutes according to the manufacturer's instructions.

The conductivity probe was immersed into the water sample ensuring that the electrodes were fully submerged and not touching the container walls.

The readings on the meter were left to stabilize for 5 minutes.

The EC and Temperature values (in $\mu\text{S}/\text{cm}$ and $^{\circ}\text{C}$ respectively) from the display were recorded.

The conductivity probe was rinsed with distilled water and stored safely in its housing.

3.4 To evaluate the iron reduction between the two methods.

To achieve this objective, the following was undertaken;

Initial Analysis

The representative groundwater samples were collected, preserved and taken to the laboratory for analysis. The initial iron concentration in the collected water samples were measured in accordance to APHA 3111B method (using direct air/ Acetylene Flame

Atomic Absorption device of Brand/Make: Shimadzu Corporation, Model Name/Number: AA-6800, Accuracy: Typically, $\pm 1-2\%$ depending on the concentration and matrix of the sample).

Experimental Setup and treatment

Setups for conventional and the PAC-based methods were made, and the groundwater samples were passed through both treatment methods for 3 times each, and the treated water (filtrate) was collected for laboratory analysis and compared to the initial analysis.

The percentage reduction of iron for each treatment method was calculated from the formular, $\frac{C_i - C_f}{C_i} \times 100$

where: C_i is the Initial iron concentration

C_f is the Final iron concentration after treatment.

3.5 To determine the adsorbent filter unit with the best performance to be implemented for iron reduction at household levels.

This objective was achieved through the following methodology (according Matsiyevska, 2020)

- Comparison of the initial Iron concentration (before treatment) to the final (after treatment) considering the Conventional method and the PAC.

- Carrying out T-test to compare the means of the Iron values (for the different adsorbent filters and the conventional treatment method)

$$T = \frac{\text{Mean 1} - \text{Mean 2}}{\frac{[(n_1 - 1) \times \text{Var1}^2] + [(n_2 - 1) \times \text{Var2}^2]}{(n_1 + n_2) - 2}} \times \sqrt{\frac{1}{n_1} + \frac{1}{n_2}}$$

Where,

Mean1 and Mean2 are the Average values of each of the sample sets

Var1 and Var2 are the Variance of each of the sample sets

n1 and n2 are the Number of records in each sample set

Degrees of Freedom is n1+n2-2 where: n1 and n2 are the number of records in each sample set

- Factor of Safety Consideration (considering class 1 and class 2 of the permissible limit of Iron in potable water)

Safety Margin calculation

$$S_m = P_l - A_c$$

Where, S_m is the safety margin

P_l is the permissible limit

A_c is the actual concentration

- Choosing the optimal filter unit.

CHAPTER 4. RESULTS AND DISCUSSION

This chapter shows the results obtained in the two methods (conventional and the use of PAC) in iron reduction and the results are been tabulated as below.

4.1 The physicochemical characteristics of the raw water

Table 1: Physicochemical characteristics of the raw water.

PARAMETER	UNIT	VALUE	UGANDA NATIONAL STANDARD FOR TREATED POTABLE WATER (2008, second edition, section 4.1, table 1, page 4.)
pH	-	7.1	6.5 - 8.5
DO	mg/L	5.9	
Temperature	°C	26.5	-
EC	µS/cm	14757	2500
Total iron	mg/L	41.44	0.3

From the table above, it clearly showed that the iron content was higher (41.44mg/L) than the permissible limit (1 mg/L) according to the Uganda National Standards for untreated potable water. Hence, this called for the reduction of the iron content from the water. The electrical conductivity of the water (14757 µS/cm) was also higher than the permissible level (2500 µS/cm) as compared to the Uganda National Standards for untreated potable water. This was possible because of the high iron content in the water in a way that, when iron is dissolved in water, it forms Iron ions (Fe^{2+} and Fe^{3+}), which can conduct electricity due to their ability to carry electric charges. In summary, higher concentrations of iron ions in water can lead to increased electrical conductivity

because there are more charged particles available in the water to conduct electricity. However, other water quality parameters like DO and pH were within the acceptable range for potable water.

4.2 The efficiency of each of the methods

Table 2: Percent reduction of each treatment method

Treatment method	C _i (mg/L)	C _f (mg/L)	Percentage (%)
Conventional	41.44	1.98	95.22
PAC based	41.44	0.33	99.20

The table above shows a comparison between the Iron reduction by both the Conventional and Powdered Activated Carbon treatment methodologies. The conventional method gives a high removal efficiency but the total Iron is still above the permissible limits by the Uganda National Standard for Treated Potable water.

Aeration and Sedimentation aided the Iron reduction but the Powdered activated carbon filtration media further reduced the concentrations below the standards according to the Uganda National Standard for Potable Treated water.

4.3 Determining the most effective PAC thickness

Table 3: Data used in determining the most effective PAC thickness

TOTAL IRON CONCENTRATION (mg/L)			
Sample A (conventional)	Sample B (PAC 2.5cm)	Sample C (PAC 5cm)	Sample D (PAC 7cm)

	1.99	0.38	0.32	0.24
	1.97	0.37	0.33	0.25
	1.98	0.38	0.34	0.25
Average	1.98	0.38	0.33	0.25
Variance	0.0001	3.3333E-05	0.0001	3.3333E-05
Standard Deviation	0.01	0.006	0.01	0.006

From the above table,

$$\text{Variance (Var)} = \frac{\sum_{i=1}^N (x_i - \mu)^2}{N}$$

Where N is size of the population

x_i is the value in the data set

μ is the mean

$$\text{Standard Deviation (SD)} = \sqrt{\text{Variance}}$$

T-test for the data in table 4 above

A t- test is a statistical test that is used to compare the means of two groups. It is mostly used in hypothesis testing to determine whether a process or treatment actually has an effect on the population of interest, or whether two groups are different from one

another. The null hypothesis (H₀) is that the true difference between these group means is zero. The alternate hypothesis (H_a) is that the true difference is different from zero

$$T = \frac{\text{Mean1} - \text{Mean2}}{\frac{[(n1-1) \times \text{Var1}^2] + [(n2-1) \times \text{Var2}^2]}{(n1+n2)-2}} \times \sqrt{\frac{1}{n1} + \frac{1}{n2}}$$

Where,

- T is the value of Iron t-test
- Mean1 and Mean2 are the Average values of each of the sample sets
- Var1 and Var2 are the Variance of each of the sample sets
- n1 and n2 are the Number of records in each sample set
- Degrees of Freedom is n1+n2-2 where: n1 and n2 are the number of records in each sample set

Comparison of sample A and B

$$T = \frac{\text{MeanA} - \text{MeanB}}{\frac{[(nA-1) \times \text{VarA}^2] + [(nB-1) \times \text{VarB}^2]}{(nA+nB)-2}} \times \sqrt{\frac{1}{nA} + \frac{1}{nB}}$$

$$= \frac{1.98 - 0.38}{\frac{[(2) \times 0.0001^2] + [(2) \times 3.33E-05^2]}{(3+3)-2}} \times \sqrt{\frac{1}{3} + \frac{1}{3}}$$

$$= 3.5475 \times 10^8$$

Comparison of sample A and C

$$T = \frac{\text{MeanA} - \text{MeanC}}{\frac{[(nA-1) \times \text{VarA}^2] + [(nC-1) \times \text{VarC}^2]}{(nA+nC)-2}} \times \sqrt{\frac{1}{nA} + \frac{1}{n}}$$

$$= \frac{1.98 - 0.33}{\frac{[(2) \times 0.0001^2] + [(2) \times 0.0001^2]}{(3+3)-2}} \times \sqrt{\frac{1}{3} + \frac{1}{3}}$$

$$= 2.0320 \times 10^8$$

Comparison of sample A and D

$$T = \frac{\text{MeanA} - \text{MeanD}}{\frac{[(nA-1) \times \text{VarA}^2] + [(nD-1) \times \text{VarD}^2]}{(nA+nD)-2}} \times \sqrt{\frac{1}{nA} + \frac{1}{nD}}$$

$$= \frac{1.98 - 0.25}{\frac{[(2) \times 0.0001^2] + [(2) \times 3.33E-05^2]}{(3+3)-2}} \times \sqrt{\frac{1}{3} + \frac{1}{3}}$$

$$= 3.8357 \times 10^8$$

Comparison of sample B and C

$$T = \frac{\text{MeanB} - \text{MeanC}}{\frac{[(nB-1) \times \text{VarB}^2] + [(nC-1) \times \text{VarC}^2]}{(nB+nC)-2}} \times \sqrt{\frac{1}{nB} + \frac{1}{n}}$$

$$= \frac{0.38 - 0.33}{\frac{[(2) \times 3.33E-05^2] + [(2) \times 0.0001^2]}{(3+3)-2}} \times \sqrt{\frac{1}{3} + \frac{1}{3}}$$

$$= 0.1109 \times 10^8$$

Comparison of sample B and D

$$T = \frac{\text{MeanB} - \text{MeanD}}{\frac{[(nB-1) \times \text{VarB}^2] + [(nD-1) \times \text{VarD}^2]}{(nB+nD)-2}} \times \sqrt{\frac{1}{nB} + \frac{1}{nD}}$$

$$= \frac{0.38 - 0.25}{\frac{[(2) \times 3.33E-05^2] + [(2) \times 3.33E-05^2]}{(3+3)-2}} \times \sqrt{\frac{1}{3} + \frac{1}{3}}$$

$$= 1.4438 \times 10^8$$

Comparison of sample C and D

$$T = \frac{\text{MeanC} - \text{MeanD}}{\frac{[(nC-1) \times \text{VarC}^2] + [(nD-1) \times \text{VarD}^2]}{(nC+nD)-2}} \times \sqrt{\frac{1}{nC} + \frac{1}{nD}}$$

$$= \frac{0.33 - 0.25}{\frac{[(2) \times 0.0001^2] + [(2) \times 3.33E-05^2]}{(3+3)-2}} \times \sqrt{\frac{1}{3} + \frac{1}{3}}$$

$$= 0.1774 \times 10^8$$

Table 4: T-values for the different paired samples

SAMPLES	T- VALUE ($\times 10^8$)
AB	3.5475
AC	2.0320
AD	3.8357
BC	0.1109
BD	1.4438

CD	0.1774

Assuming a 5% significance,

Using the degree of freedom value as 2 and a 5% level of significance, a t-value of 4.303 was obtained from the distribution table at a confidence level of 95%.

Comparing the value (4.303) against the computed t-values show clearly that the calculated t-values are greater than the table value at a significance level of 5% and confidence level of 95%

Therefore, it is safe to reject the null hypothesis that there is no difference between means. The population sets have intrinsic differences, and they are not by chance.

The initial iron concentration is 41.44 mg/L, significantly exceeding the permissible limit of 0.3 mg/L according to the Uganda National Standard for treated portable water.

The conventional method reduced the iron concentration to 1.98 mg/L which still exceeds the permissible limit 0.3mg/L.

Table 5: Performance of PAC

PAC depth (cm)	Reduced Iron level (mg/L)	Safety Margin (mg/L)
2.5	0.35	0.05
5	0.33	0.03
7.5	0.25	0.05

Factor of Safety Consideration

A factor of safety accounts for uncertainties and ensures robustness. The filter unit that not only meets the permissible limit but also provides a safety margin was chosen as follows.

Safety Margin = Permissible Limit - Actual Concentration

For the 2.5 cm PAC depth:

Safety Margin = 0.3 mg/L - 0.35 mg/L = -0.05 mg/L (negative margin)

For the 5 cm PAC depth:

Safety Margin = 0.3 mg/L - 0.33 mg/L = 0.03 mg/L (positive margin)

For the 7.5 cm PAC depth:

Safety Margin = 0.3 mg/L - 0.25 mg/L = 0.05 mg/L (positive margin)

Choosing the Optimal Filter Unit

Considering the factor of safety, a positive safety margin is considered, the 5 cm PAC depth filter unit provides the best balance of which it achieves close to the desired iron concentration of 0.3 mg/L, it maintains a positive safety margin of 0.03 mg/L, and it falls within the acceptable limit for Class 2 (1 mg/L).

Therefore, based on scientific reasoning and the factor of safety, I recommend using the adsorbent filter with a 5 cm PAC depth for your household iron reduction. This choice ensures compliance with regulations while providing a safety buffer against variations

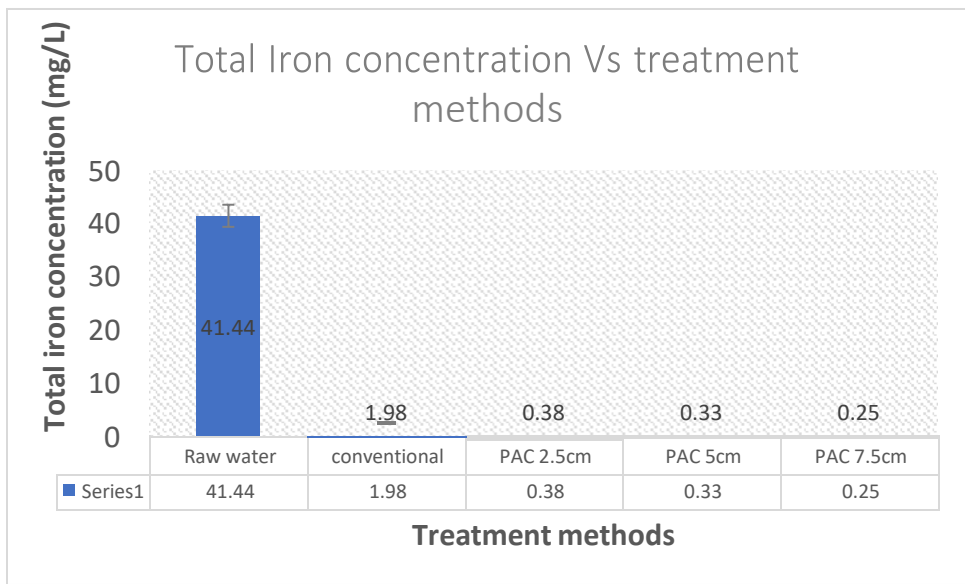

Figure 1: Total Iron reduction

The values of total iron are observed decrease from the raw data to the treated water. The conventional method removed up to 95.22% still failed to comply with the Uganda National Standards of both Class 1(Treated potable water) and Class 2(Untreated potable water). In the PAC based method, the iron levels were decreasing with the increasing PAC depth. Therefore, increased PAC depth in the adsorbent filters provided

thicker carbon layers through which the water under treatment had to pass before exiting the filter hence, it provided more contact time between the water and the PAC particles that allowed more adsorption of iron ions. As a result, a greater proportion of iron ions present in the water was captured and retained by the PAC as it passed through the deeper layers of the filter.

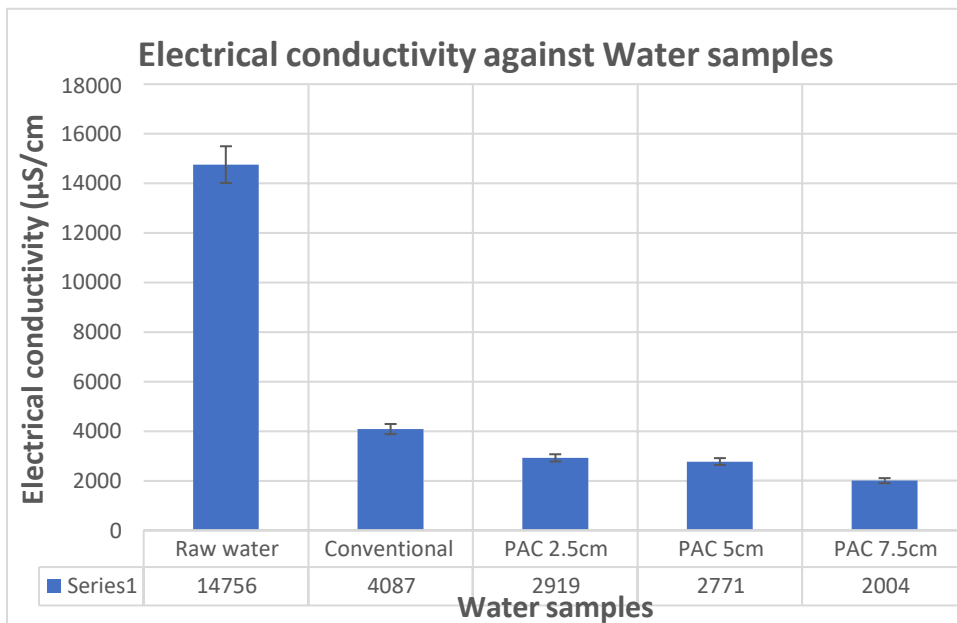

Figure 2: Electrical Conductivity for the different water samples

The Electrical Conductivity is as well observed to reduce from the raw water through the conventional and powdered activated carbon treatment processes. This implies a reduction in the concentration of dissolved charged Iron ions within the water (London, 2019). From figure 2 above, it can be noted that electrical conductivity increases with increasing iron levels and reduces with reducing iron levels.

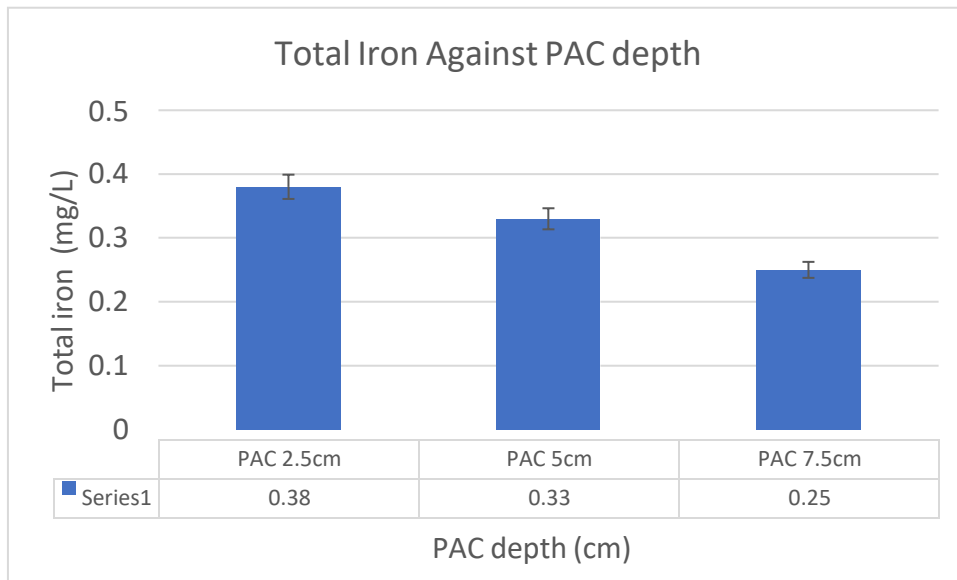

Figure 3: Total Iron Concentrations against PAC depth

In Figure 3 above, a reduction in the concentration of total Iron with increase in the Powdered Activated Carbon filter media depth was observed. This was because increasing PAC depth leads to longer interactions between the iron ions and the PAC thus prolonged adsorption process leading to decreasing iron level present in the water sample.

A phosphate test was also carried out for the treated water from the Conventionally treated water, PAC 2.5cm, PAC 5cm, and PAC 7.5cm to confirm whether there was no residual phosphates content arising from the PAC that had been chemically activated with Phosphoric Acid. The results from the phosphate strips gave that there were no residual phosphates within the treated water as it gave 0ppm of Phosphates.

DESIGN FLOWS (HOUSEHOLD SCALE)

REFERENCE	CALCULATIONS	OUT PUT
LC 1 Office Kanooni	<p>Design flows (household scale)</p> <p>Assumed design period is 6 years (because it is a small scale treatment system)</p> <p>Population per household is 8 people</p> <p>Population growth rate is 3.06 %</p> <p>Population projection in 6 years is given by,</p> $P_n = P(1+r)^n$ <p>Where P_n is the population after n years</p> <p>P is the current population</p> <p>r is the population growth rate</p> <p>n is the design period in years</p> $P_n = 8(1+0.0306)^6 = 10 \text{ people}$	
Water Supply Design Manual (2014)	<p>Water demand is 50l/Ca/d (for all domestic uses)</p> <p>Flow through $Q = \text{water demand} \times \text{population}$</p> $= 50 \times 10$ $= 500 \text{ l/d} = 5.79 \times 10^{-6} \text{ m}^3/\text{s}$ <p>Conduit diameter is 20mm = 0.02 m</p> $\text{Area (A)} = \frac{MD^2}{4} = \frac{M \times 0.02^2}{4} = 0.00031 \text{ m}^2$ <p>Velocity</p> <p>From continuity equation,</p>	<p>10 people</p> <p>$5.79 \times 10^{-6} \text{ m}^3/\text{s}$</p> <p>0.00031 m²</p>

<p>H. Kudela (2016)</p>	<p>$Q = Av$</p> <p>Where Q is the flow through in m/s</p> <p>A is the cross-sectional area of the conduit</p> <p>v is the velocity through the conduit</p> $V = \frac{Q}{A} = \frac{5.79 \times 10^{-6}}{3.1 \times 10^{-4}} = 1.87 \times 10^{-2} \text{ m/s}$ <p>Reynold's number (Re)</p> $Re = \frac{vD}{\nu}$ <p>Where Re is Reynold's number</p> <p>v is velocity of the pipe</p> <p>D is diameter of the pipe</p> <p>ν is kinematic viscosity of water</p> <p>but ν is $1.01 \times 10^{-6} \text{ m}^2/\text{s}$</p> $Re = \frac{0.0187 \times 0.02}{1.01 \times 10^{-6}} = 370.3$ <p>Since $Re < 2000$, the pipe has laminar flow</p> <p>Pressure drop</p> <p>From Poiseuille's equation, $Q = \frac{M\Delta P r^4}{8\eta L}$</p> <p>Where Q is the flow through</p> <p>ΔP is the pressure drop</p> <p>r is the pipe radius</p> <p>η is the kinematic viscosity</p>	<p>$1.87 \times 10^{-2} \text{ m/s}$</p> <p>370.3</p> <p>laminar flow</p>
-----------------------------	--	--

4.4 SYSTEM DESIGN (Lab scale)

REFERENCE	CALCULATIONS	OUT PUT
(Kamal, 2007)	<p><u>DESIGN OF THE FILTER</u></p> $\text{Area of filter} = \frac{\text{Capacity}}{\text{Rate of filtration}}$ $\text{Rate of filtration} = \frac{\text{Filtrate volume}}{\text{Surface area of filter}} \div \text{Time}$ $= \frac{0.00055}{0.0044} \div 0.0093$ $= 13.44 \text{ m}^3/\text{m}^2/\text{h}$ $\text{Capacity} = \frac{\text{Volume}}{\text{Time}}$ $= \frac{0.00055 \text{ m}^3}{0.009328 \text{ hr}} = 0.059 \text{ m}^3/\text{h}$ $\text{Area} = \frac{0.059}{13.44} = 0.0044 \text{ m}^2$	<p>13.44m³/m²/h</p> <p>0.059 m³/h</p> <p>0.0044 m²</p>
(Vouchkov, 2005)	<p><u>DESIGN OF SETTLING TANK</u></p> <p>Width to length ratio= (3:1 to 5:1) = (WTPD fourth edition section 7.5)</p> <p>Water demand = 14L/capita/day (WSDM second edition section 2-4)</p> <p>Average population per household = 8 people (Lc 1 Kanoni Village)</p>	

	<p>Assume a circular area,</p> $\text{From } A = \frac{\pi D^2}{4}$ $D = \frac{\sqrt{4A}}{\pi} = \frac{\sqrt{(4 \times 0.0862)}}{\pi} = 0.3313 \text{ m}$ <p>Depth (H) of the tank</p> <p>From volume (V) = Area (A) × Depth (H)</p> $H = \frac{V}{A} = \frac{0.0058}{0.0862} = 0.0673 \text{ m}$ <p>Therefore, provide a settling tank of the following dimensions;</p> <p>Diameter = 0.3313 m = 331 mm</p> <p>Depth = 0.0673 m = 67.3 mm.</p> <p>Width to depth ratio = $\frac{331}{67.3} = 4.9 : 1$ which is within</p> <p>the range required by the water supply design manual second edition</p>	0.3313 m
--	---	----------

CHECK ON THE HEAD LOSSES DUE TO FRICTION IN THE FEEDING PIPES

$$H_f = \frac{4flv^2}{2gd}$$

Where H_f is the head loss due to friction

f is the friction factor

l is the length of the pipe

v is the velocity of the flow in the pipe

g is the gravity

d is the diameter of the pipe

but $f = \frac{16}{Re}$ where Re is the Reynold's number

$$f = \frac{16}{Re} = \frac{16}{370.3} = 0.0432$$

$$g = 9.81 \text{ m}^2/\text{s}$$

$$d = 0.02\text{m}$$

Figure 4: Lab scale prototype showing the settling tank and the feeding pipes

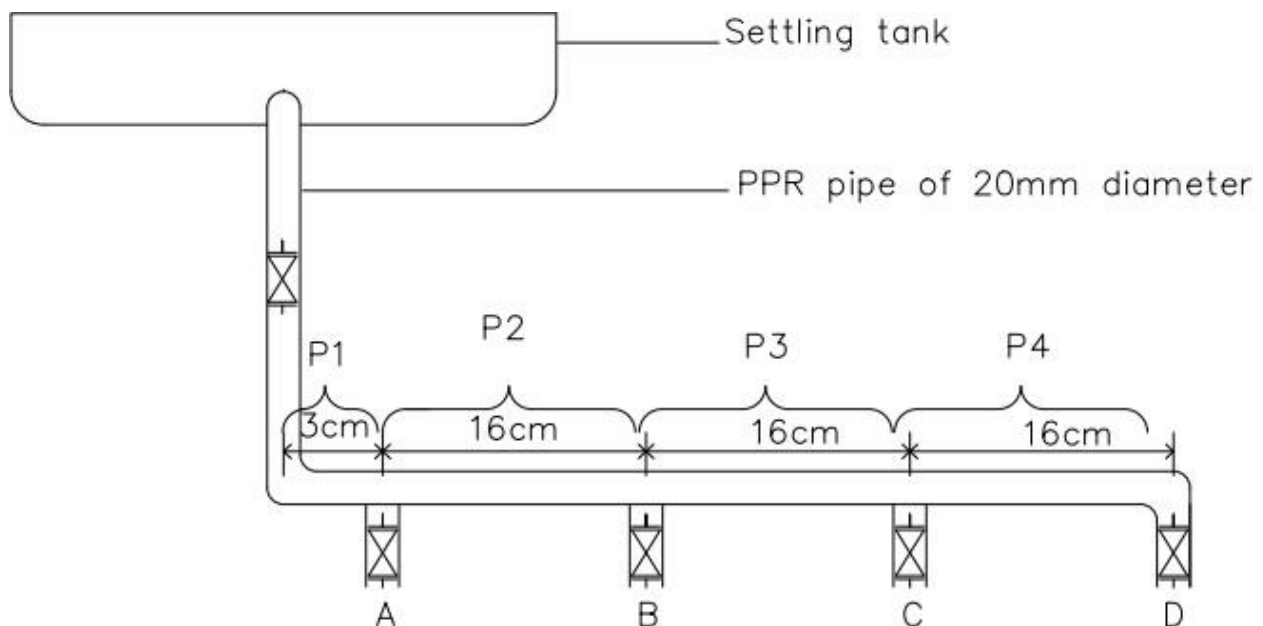

A, B, C, and D, are the feeding pipes to the filters. Refer to Appendix D(a) on page 42 for more detailed drawings.

Pipe 1(P1)	Pipe 2(P2)	Pipe 3(P3)	Pipe 4(P4)
L=3cm	L=19cm	L=35cm	L=51cm
d = 20mm	d = 20mm	d = 20mm	d = 20mm
$H_f = \frac{4flv^2}{2gd}$	$H_f = \frac{4flv^2}{2gd}$	$H_f = \frac{4flv^2}{2gd}$	$H_f = \frac{4flv^2}{2gd}$
=	=	=	=
$\frac{4 \times 0.0432 \times 0.03 \times 0.0187^2}{2 \times 9.81 \times 0.02}$	$\frac{4 \times 0.0432 \times 0.19 \times 0.0187^2}{2 \times 9.81 \times 0.02}$	$\frac{4 \times 0.0432 \times 0.35 \times 0.0187^2}{2 \times 9.81 \times 0.02}$	$\frac{4 \times 0.0432 \times 0.51 \times 0.0187^2}{2 \times 9.81 \times 0.02}$
= 4.62×10^{-6} m	= 2.93×10^{-5} m	= 5.39×10^{-5} m	= 7.85×10^{-5} m

Therefore, from the above calculations, the head losses are so small (Balsiger, 2014) that they can be neglected because they have negligible effect on the flow through the feeding pipes.

CHAPTER 5. CONCLUSIONS AND RECOMMENDATIONS

5.1 Conclusions

The physicochemical characteristics (pH, DO, EC, temperature and total iron content) of the raw water were determined (using APHA 4500- H B, APHA 4500-O G, Electrometric Method for EC and Temperature, and APHA 3111 B respectively) and the results showed that the iron content was higher (41.44mg/L) than the permissible limit (1 mg/L) according to the Uganda National Standards for untreated potable water. Hence, this called for the reduction of the iron content from the water.

The iron was evaluated and the iron reduction (by the conventional method and the use of PAC in an adsorbent filter) was compared under time constraints and the treated water quality was compared with Uganda treated potable water standards. The conventional method reduced the iron to 1.98mg/L (which was still higher compared to the permissible limit of 0.3mg/L according to the Uganda National Standards for treated potable water), the PAC in the adsorbent filters reduced the iron to 0.38mg/L, 0.33mg/L, and 0.25mg/L with the PAC depth of 2.5cm, 5cm, and 7.5cm respectively. However, The Powdered Activated Carbon-based treatment method gave a better iron reduction than the conventional method as it even reduced the iron levels below the permissible limit according to the Uganda National Standard for Treated potable water.

The adsorbent filter unit with the best performance was determined (after carrying out T-tests to compare the PAC depth performances and factor of safety considerations) to be used for iron reduction at the household levels. However,

the 5 cm PAC depth filter unit provided the best balance of which it achieved close to the desired iron concentration of 0.3 mg/L, it also maintained a positive safety margin of 0.03 mg/L and it fell within the acceptable limit for Class 2 (untreated potable water) which is 1 mg/L.

5.2 Recommendations

From the conclusions above, it shows clearly that a comparative study (between the conventional method and the PAC based method) was successfully conducted in which PAC was a better option to reduce iron from ground water.

Therefore, I recommend that more research should be done through carrying out mass balance equations in order to achieve neutralization reactions for the Iron. The phases and species may as well need to be further examined and understood so as to achieve efficient removal of Iron from the groundwater.

I as well recommend more studies and research on the optimum thickness of PAC in an adsorbent filter which can reduce the total iron exactly to the permissible limit of 0.30mg/L which is accepted by the Uganda National Standards for treated potable water. This should be done in order to provide an informed decision on a proper PAC depth to avoid cases of either over estimation or under estimation of the PAC depth for proper resource (PAC) allocation.

APPENDICES

APPENDIX A: MATERIAL PREPARATION



Washing the raw Sawdust



Dried raw sawdust



Carbonized sawdust



Impregnating the carbon with acid

APPENDIX B: FIELD VISIT



Sample collection



Data collection from Lc 1 chair person



Abandoned borehole due to high iron



Local people in search of cleaner water

APPENDIX C: LABORATORY ACTIVITIES



Testing Dissolved Oxygen



Prototype setup

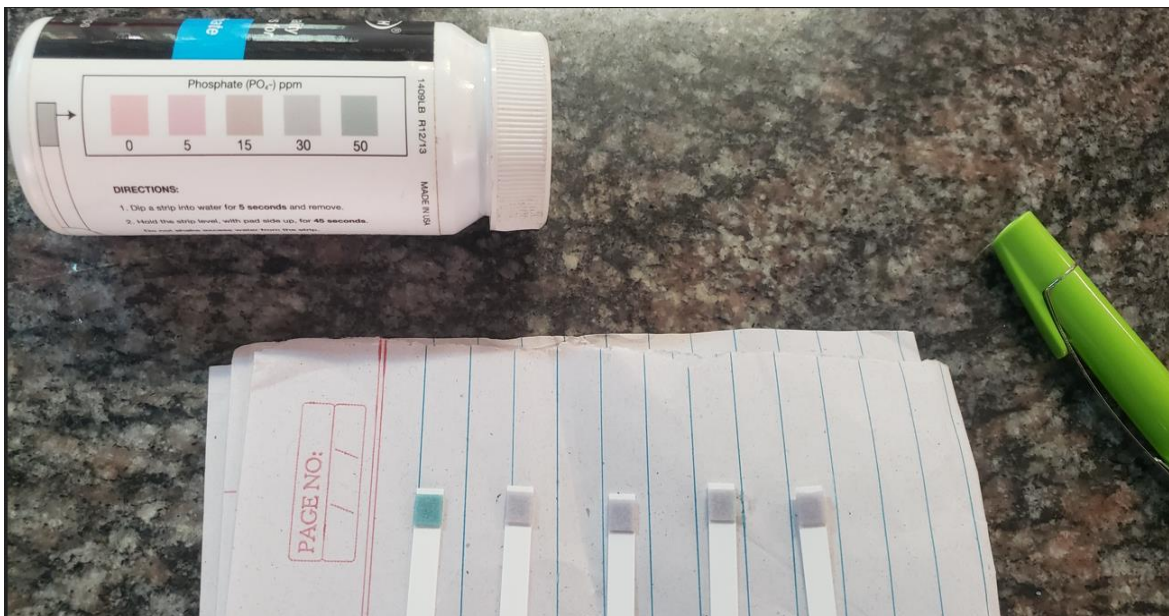

Phosphate strips for the raw water, conventional treatment, PAC 2.5cm, PAC 5cm and PAC 7.5cm respectively

(a) LAB SCALE (used in experiments)

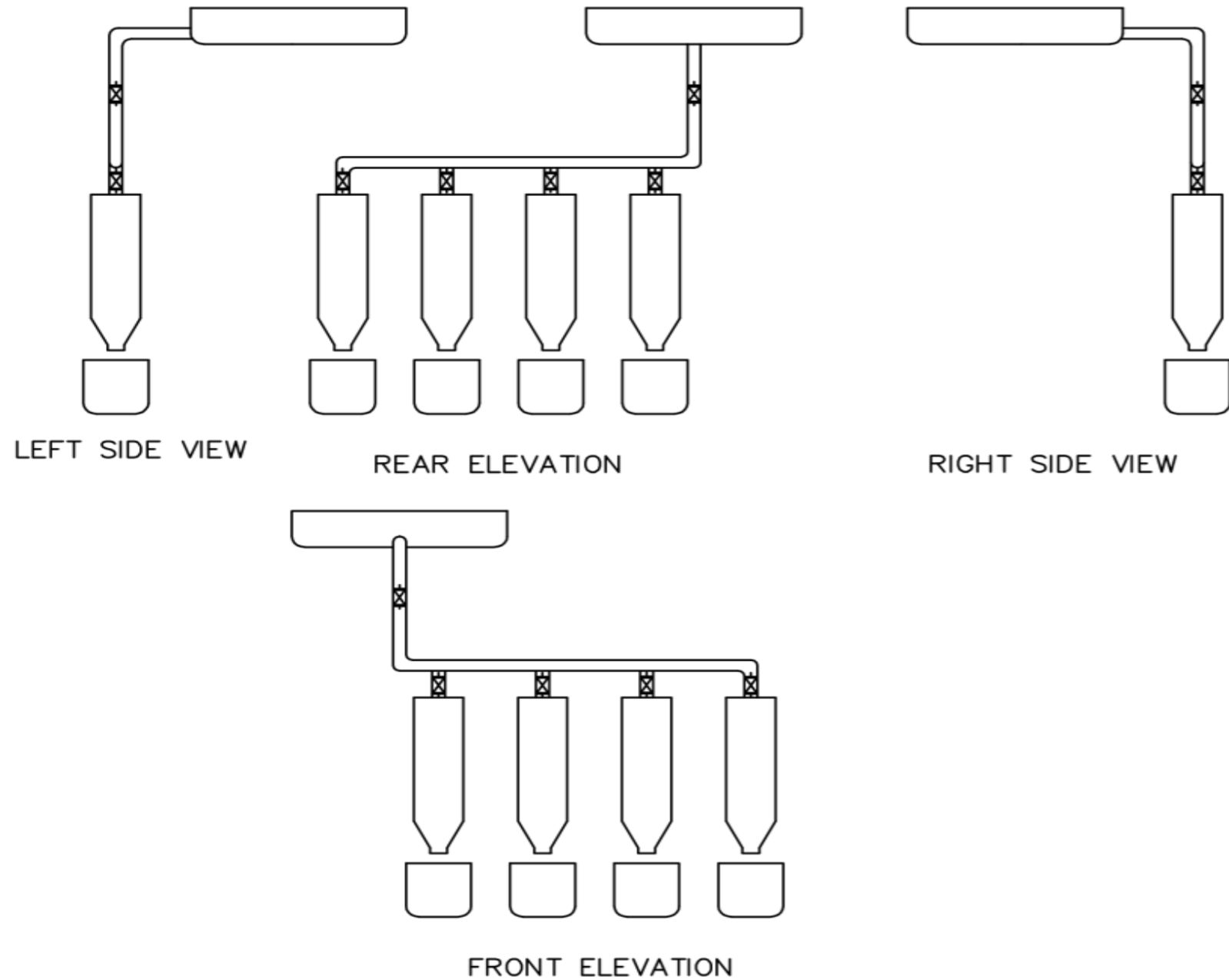

SYM	ZONE	DESCRIPTION	REVISION	DATE	APPROVAL

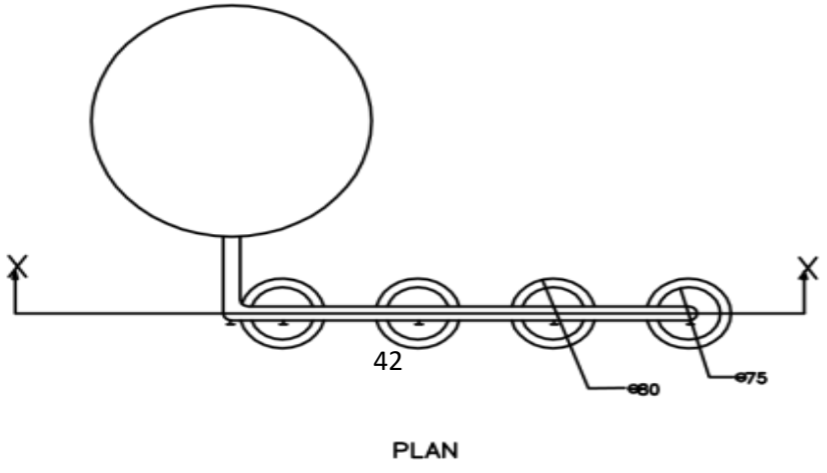
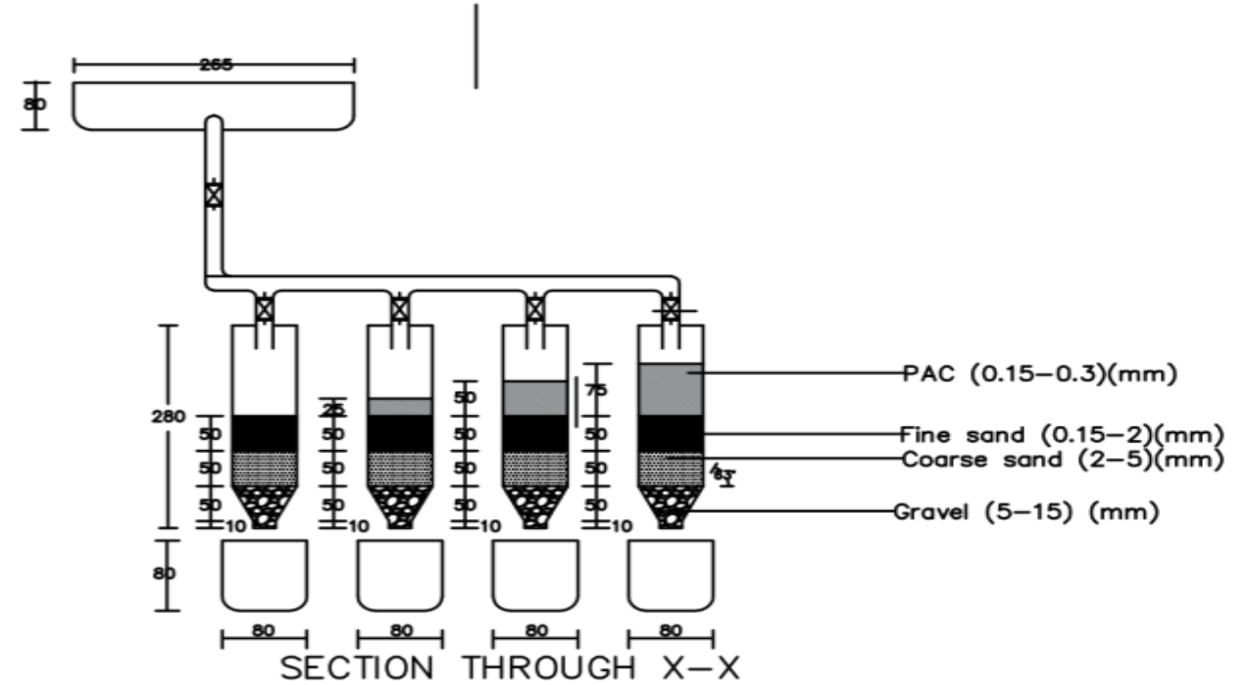

ITEM NO	REQD	REQD PART NO	DESCRIPTION	MATERIAL	MATERIAL SPEC AND NO
LIST OF MATERIAL					
UGANDA CHRISTIAN UNIVERSITY BSCEE FYP					
NAME			INIT	DATE	DRAWING INTERPRETED PER GSFC-X673-64-1
DESIGNER: ERIC M AND ANDREW M				24/03/2024	
DRAWN: ERIC M AND ANDREW M				24/03/2024	
CHECKED: ENG. DR.WOZEI E					
THIS DRAWING WAS PRODUCED USING			MECHANICAL ENGINEER		
SOFTWARE: AUTOCAD VERSION: 2019			SYSTEM ENGINEER		
FILE NAME: LAB SCALE			ELECTRICAL ENGINEER		
NEXT ASSY			STRESS ENGINEER		
USED ON			GD		

METRIC HYBRID
METRIC/INCH

FIRST ANGLE PROJECTION

UNLESS OTHERWISE SPECIFIED, DIMENSION ARE IN MM

DIMENSION TOLERANCES
2 DECIMAL ±0.25
1 DECIMAL ±0.5
ANGLE ±1°
RAD/CHAM ±0.5

3.2 FINISH IN MICROMETERS

REMOVE ALL BURRS AND SHARP EDGES R 0.25 OR CHAMFER MAX

(b) HOUSEHOLD SCALE

SYM	ZONE	DESCRIPTION	REVISION

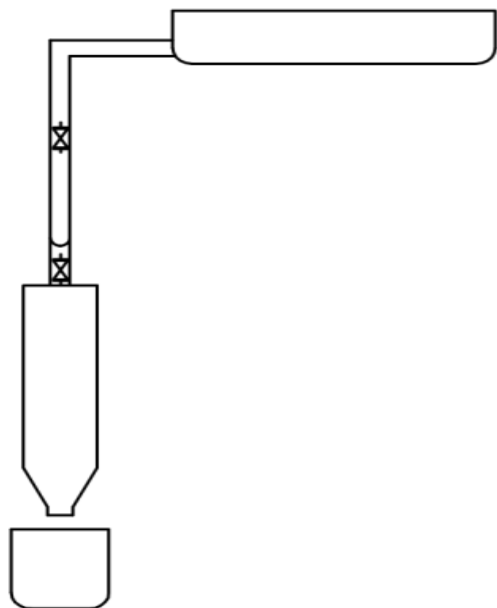

LEFT SIDE VIEW

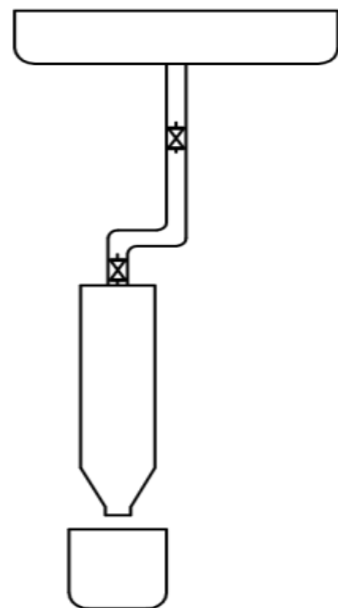

REAR ELEVATION

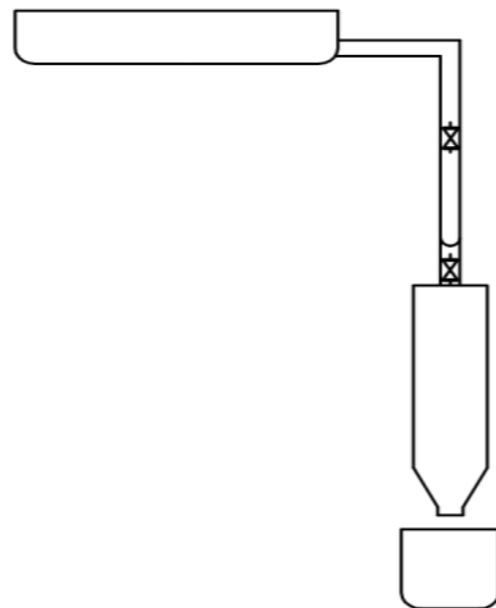

RIGHT SIDE VIEW

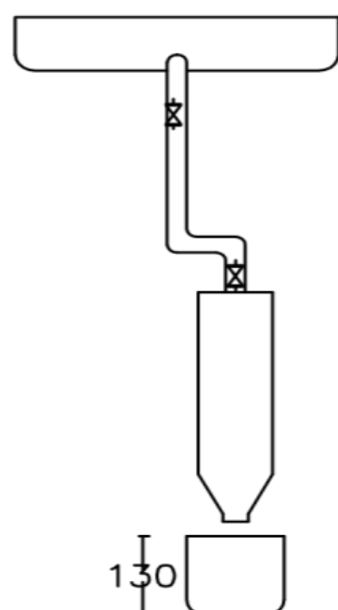

FRONT ELEVATION

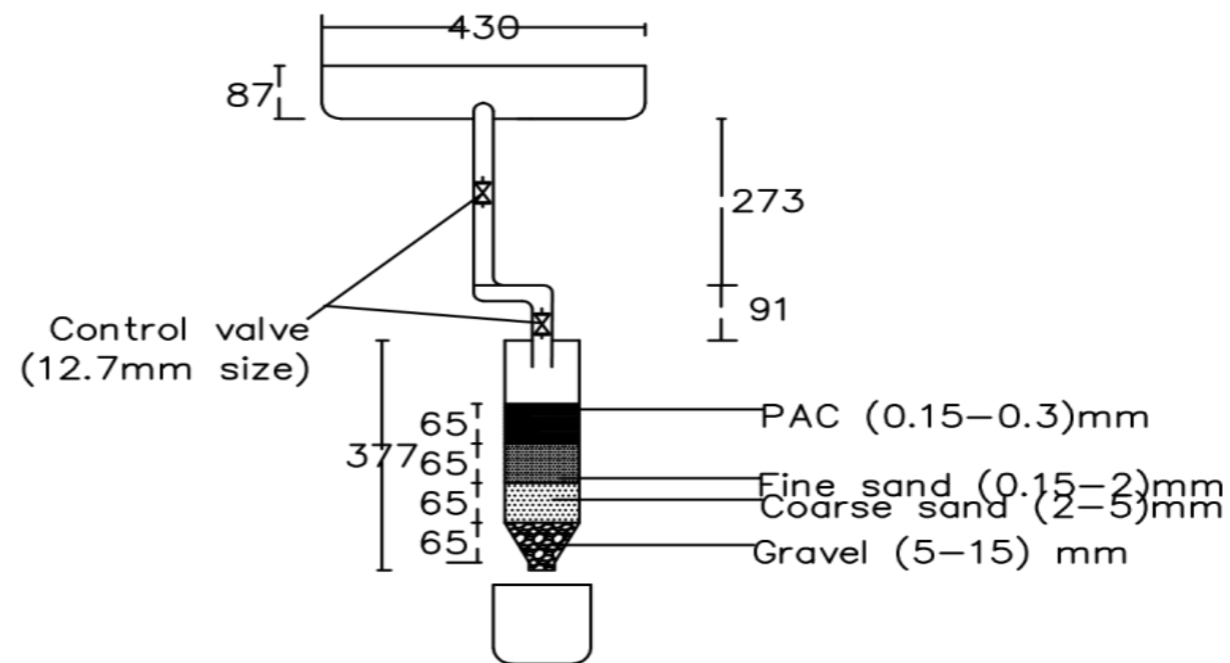

SECTION THROUGH A-A

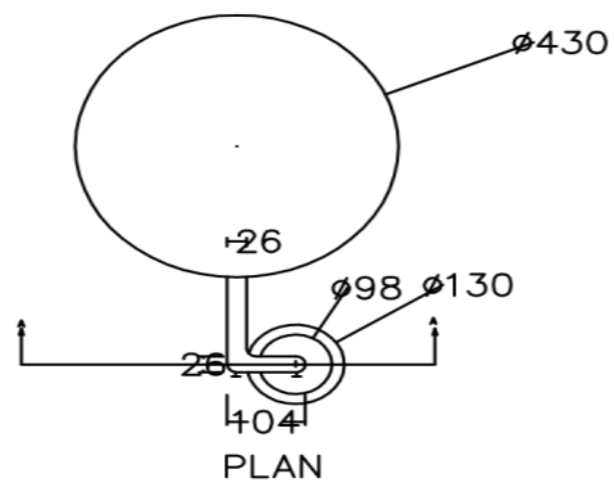

PLAN

ITEM NO	REQD	REQD	PART NO	DESCRIPTION	MATERIAL

<p>METRIC HYBRID METRIC/ INCH</p> <p>FIRST ANGLE PROJECTION</p> <p>UNLESS OTHERWISE SPECIFIED, DIMENSION ARE IN MM</p> <p>DIMENSION TOLERANCES</p> <p>2 DECIMAL ±0.25</p> <p>1 DECIMAL ±0.5</p> <p>DECIMAL ±1</p> <p>ANGLE ±1°</p> <p>RAD/CHAM ±0.5</p> <p>REMOVE ALL BURRS AND SHARP EDGES R 0.25 OR CHAMFER MAX</p>		<p>3.2 FINISH IN MICRO-METERS</p>
---	--	-----------------------------------

LIST OF MATERIAL				
NAME	INIT	DATE	DRAWING INTERPR	
DESIGNER: ERIC M AND ANDREW M		24/03/2024	TITLE: THE HOUSEHOLD S USED IN THE IRON	
DRAWN: ERIC M AND ANDREW M		24/03/2024		
CHECKED: ENG. DR.WOZEI E				
MECHANICAL ENGINEER				
SYSTEM ENGINEER				
			ELECTRICAL ENGINEER	
			STRESS ENGINEER	
				GD

THIS DRAWING WAS PRODUCED USING SOFTWARE: AUTOCAD VERSION: 2019 FILE NAME: LAB SCALE

NEXT ASSY USED ON

APPENDIX E: CERTIFIED LAB REPORTS

	<p>TIMES ANALYTICS LIMITED Field to Laboratory Analytical Services Excellency, Plot 1089, Church Road, Kitintale, Kampala, Uganda P.O. Box 74609 Clock-Tower Tel: 0778065015/ 0705956283 E-mail: times.analytics@gmail.com</p>
Page 1 of 1	

Client: Eric Manede/ Andrew Mbabali Address: BSc. Civil & Environmental Engineering-UCU Mukono Project: Rakai Borehole (UCU Student Research) No. of Samples: 01- Water (Lab No. UCU/W/24-024) Mobile: 0771550086 Reception Date: 1.2.2024 13:13hrs Sampler: Client	Ref: RTAL 24-011 Issue Date: 2 nd Feb 2024
--	--

TEST REPORT

Parameter	Test Method	D.O.A	Value	US EAS 12:2014 LIMIT
Total Iron, mg/L	APHA 3111 B	1-2-24	41.44	0.3

*****END OF TEST REPORT*****

Please note:

- **US EAS12: 2014** is the Uganda Standard as adopted from the East African Standard for natural potable water of which borehole water is part.
- D.O.A is Date of Analysis.
- The test methods are adopted from **APHA 23rd Edition of 2017** (Standard Test Methods for the Examination of Water and Wastewater)
- APHA 3111B Method is direct Air/ Acetylene flame Atomic Absorption (FAAS)
- This sample is a gross nonconformance to the specification in accordance with US EAS12:2014 and can therefore not qualify to be used as potable water.

Analyst



 George Mugambwa

Laboratory Manager



 Daniel Okwako

*Test results in this certificate relate only to the items as received.
 This document is not reproducible except in full without written approval from TAL. Any unauthorized alteration and falsification of this document is unlawful and offenders may be prosecuted to the fullest extent of law.*

Times Analytics Limited is a registered testing laboratory



BIOCORE LABORATORY

Environment conservation is our responsibility



TEST REPORT

Certificate Number: BEL/005/01/2024		
Client Name: ANDREW MBABALI & ERIC MANEDE	Sample Receipt Date: 29/01/2024	Analysis Start Date: 30/01/2024
Client Address and contact: UGANDA CHRISTIAN UNIVERSITY 0759304095		
Lab Sample ID: A007/2024, A008/2024	Date of analysis completion: 31/01/2024	Date of issue of the certificate: 01/02/2024
Client Sample ID: Treated and untreated Borehole water		
Sample type and Location: Borehole water from Rakai District		
State of the sample on delivery: Water in two 5ltr jerricans	Testing conditions: Relative humidity: 68.3% Temperature: 25.4	

Parameter(s)	Test Results				
	Units	Sample A (aeration treated)	Sample B (un treated)	Test Method(s) Used	East African Standard for natural portable water 2022
pH	NTU	6.94	7.1	APHA 4500- H B	5.5-9.5
Dissolved Oxygen	mg/l	6.5	5.9	APHA 4500- O G	6-8
Temperature	degrees	26.6	26.5	Electrometric Method	-
Electrical Conductivity	µs/cm	14,993	14,756	Electrometric Method	2500

REMARKS:

Results do apply only for the sample as it was received and analysed. The client bears sampling responsibility as the representative characters of the sample delivered.
mg/L- stands for milligrams per liter.

Tested by: BIOCORE ENTERPRISES
Quality Analyst LIMITED
[Signature]

Approved By:
Laboratory Manager
[Signature]

This Certificate of analysis is only valid if it bears an authorised signature and an official stamp. It may not be reproduced other than in full, except with written approval from the Laboratory Manager Biocore Laboratory.



BIOCORE ENTERPRISES LIMITED

"Environment Conservation Is Our Responsibility"

Namabwe Industrial Park - Ssempala Road
P.O. Box 892, Kampala. Tel: 0393 228 012, Email: biocorenter@gmail.com

01.02.2024

Raw data

Client Name: ANDREW MBABALI & ERIC MANEDE

NO	PARAMETER	RESULTS	
		Treated borehole water	Untreated borehole water
01	pH	6.85	7.23
		6.94	6.95
		7.04	7.01
02	Dissolved oxygen	6.50	5.92
		6.49	5.90
		6.51	5.81
03	Temperature	26.5	26.5
		26.7	26.5
		26.7	26.5
04	Electrical Conductivity	14,970	14,780
		15,020	14,730
		14,990	14,760

Signed by



Telephone
+256 (0) 414 250 464 (Gen)
+256 (0) 414 250 474
Email: dgal@mia.go.ug
Website: www.mia.go.ug

In any Correspondence on
this subject please
quote No...**GE 102/2024**....



MINISTRY OF INTERNAL AFFAIRS
DIRECTORATE OF GOVERNMENT
ANALYTICAL LABORATORY
Plot No. 2 Lourdel Road
Wandegeya,
P.O. BOX 105639
Kampala - Uganda

06th March 2024

MR. MANEDE ERIC AND MR. MBABAALI ANDREW
REG. NO. S15B32/445 AND S20B32/261
UGANDA CHRISTIAN UNIVERSITY
P.O BOX 4,
MUKONO-UGANDA
Tel: 256-771-550086

REPORT OF ANALYSIS

Description of the Samples

Four samples in falcon tubes containing water samples was submitted by Mr. Manede Eric, on 04th March 2024, and analysed on 05th March 2024. A summary of the sample received is shown in table below

S/N	Description	Quantity	Assigned Lab ID
1	Water samples packed in (4) falcon tubes labeled "A, B, C & D"	4	Water Samples GE 102/2024

Analysis Requested

Total Iron

Method of Analysis

Analysis of Total Iron was analysed using the AAS method,

Results of Analysis

The mean analysis values are as below,

Test/Parameter	Results GE 102/2024 Portable water				US EAS 12: 2014 Potable water - Specification
	A	B	C	D	
Total Iron, (Fe)	1.98	0.38	0.33	0.25	0.3 mg/L, Max

Remarks

1. The samples "B, C & D" GE 102/2024 above was analysed and found to comply with Ugandan Standard specification US EAS US 12:2014 Potable water - Specification for the parameters analysed.
2. Sample "A" GE 102/2024 above was analysed and found **not to comply** with Ugandan Standard specification because the analysed value was above the maximum limit.
3. Results relate to samples analyzed and are reported as on received basis.

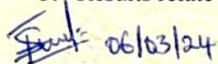
Semalago Fredrick
Government Analyst

SUMMARY OF THE RESULTS (GE 102/2024)				
Raw Data for Portable Water (triplicate Readings)				
Sample Codes	A	B	C	D
mg/L	1.99	0.38	0.32	0.24
mg/L	1.97	0.37	0.33	0.25
mg/L	1.98	0.38	0.34	0.25
AVERAGE	1.98	0.38	0.33	0.25
SD	0.01	0.006	0.01	0.006

[Handwritten signature] 26/3/24



UGANDA CHRISTIAN UNIVERSITY

A Centre of Excellence in the Heart of Africa

FACULTY OF ENGINEERING, DESIGN, AND TECHNOLOGY
Department of Engineering and Environment

TREATED WATER TESTS RESULT

Parameters	Test Sample Sites				Test Method	Uganda National Standards for treated Portable Water (US EAS 12:2014)
	Sample A (Conventional)	Sample B (2.5 CM PAC)	Sample B (5cm PAC)	Sample D (7cm PAC)		
pH	6.99	6.87	6.72	6.70	APHA 4500-HB	6.5-8.5
	6.98	6.88	6.73	6.69		
	7.01	6.88	6.71	6.69		
Temperature (°C)	25.9	26.5	25.7	25.4	Electrometric Method	-
	25.8	26.5	25.7	25.5		
	25.9	26.6	25.5	25.4		
DO (ppm)	25.6	25.5	26.0	25.4	APHA 4500-OG	6.5-8 mg/l
	25.5	25.6	26.1	25.6		
	25.6	25.5	26.2	25.5		
EC (µS/cm)	4140	2920	2770	2006	Electrometric Method	2500 µS/cm
	3980	2917	2773	2001		
	4141	2919	2771	2004		

[Signature]
Eddie Ojara
Laboratory Instructor

UGANDA CHRISTIAN UNIVERSITY
H.O.D.
Rogers Tayebwa
Head of Department - Engineering & Environment

A Complete Education for A Complete Person

PO Box 4, Mukono, Uganda | Tel: (+256) 312 350 632 | (+256) 794 770 128 | Email: eng-envt@ucu.ac.ug | Web: www.ucu.ac.ug

Founded by the Province of the Church of Uganda. Chartered by the Government of Uganda

References

CPLabSafety, 2023. *Chemical Resistance Information for Plastic Bottles, containers and Safety Cans*. [Online].

Hanna Andersson, J. J., 2002. *Iron Removal from Groundwater in Rakai District, Uganda*, s.l.: Lulea University of Technology.

Temitayo E. Oladimenji, B. O. O., 2021. *Production of Activated carbon from Sawdust and its efficiency in the treatment of Sewage water*, s.l.: ScienceDirect.

University, L., 2020. *Water Sampling*. s.l.:s.n.

Abdelhafeez, A. A., Oyelola, O. T., & Odetoyinbo, P. O. (2020). Removal of iron from groundwater using low-cost

Ahmad, M. A., Bello, O. S., Al-Othman, Z. A., & Alwarthan, A. A. (2015). Adsorption of phenolic compounds on activated carbon—A review. *Journal of Industrial and Engineering Chemistry*, 21, 18-28.

Suryawanshi, M., Bandgar, A., Mhaske, C., & Shetty, S., 2020. PRODUCTION OF ACTIVATED CARBON FROM VARIOUS NATURAL RESOURCES AND ITS APPLICATION. *Journal of emerging technologies and innovative research*.

DhanaRamalakshmi, R., Murugan, M., & Jeyabal, V. (2020). Arsenic removal using *Prosopis spicigera* L. wood (PsLw) carbon-iron oxide composite. *Applied Water Science*, 10. <https://doi.org/10.1007/s13201-020-01298-w>.

Nambatingar, N., Theophile, M., & Mianpeureum, T., 2021. Evaluation of Heavy Metals in Drinking Water Resources in the Department of Nyan, Province of Logone Oriental in Chad. *American Journal of Applied Chemistry*, 9, pp. 13. <https://doi.org/10.11648/J.AJAC.20210901.13>.

O'Hanlon, F., 2021. Rainwater Harvesting and Community Water Security in south-west Uganda. . <https://doi.org/10.17863/CAM.73570>.

Baharudin, F., Hamzah, N., Wahab, M., & Kang, C., 2021. Effectiveness of powdered activated carbon from fruit waste in removing heavy metals in groundwater. *IOP Conference Series: Earth and Environmental Science*, 646. <https://doi.org/10.1088/1755-1315/646/1/012024>.

Srivastava, K., Awasthi, S., Mishra, P., & Srivastava, P., 2020. Biosensors/molecular tools for detection of waterborne pathogens. , pp. 237-277. <https://doi.org/10.1016/b978-0-12-818783-8.00013-x>.

Al-Taai, S., 2021. Water pollution Its causes and effects. *IOP Conference Series: Earth and Environmental Science*, 790. <https://doi.org/10.1088/1755-1315/790/1/012026>.

Brindha, K., Paul, R., Walter, J., Tan, M., & Singh, M., 2020. Trace metals contamination in groundwater and implications on human health: comprehensive assessment using hydrogeochemical and geostatistical methods. *Environmental Geochemistry and Health*, 42, pp. 3819 - 3839. <https://doi.org/10.1007/s10653-020-00637-9>.

Beek, C., Hofman-Caris, C., & Zweere, G., 2020. Drinking water treatment and chemical well clogging by iron(II) oxidation and hydrous ferric oxide (HFO)

precipitation. *Journal of Water Supply Research and Technology-aqua*, 69, pp. 427-437. <https://doi.org/10.2166/aqua.2020.140>.

Şenol, N., & Şahin, M., 2023. Protective Effect of Juglone (5-Hydroxy-1,4-naphthoquinone) against Iron- and Zinc-Induced Liver and Kidney Damage. *Applied Sciences*. <https://doi.org/10.3390/app13042203>.

Usman, U., Yusoff, I., Raov, M., & Hodgkinson, J., 2020. Trace metals geochemistry for health assessment coupled with adsorption remediation method for the groundwater of Lorong Serai 4, Hulu Langat, west coast of Peninsular Malaysia. *Environmental Geochemistry and Health*, pp. 1-21. <https://doi.org/10.1007/s10653-020-00543-0>.

Zhang, Z., Xiao, C., Adeyeye, O., Yang, W., & Liang, X., 2020. Source and Mobilization Mechanism of Iron, Manganese and Arsenic in Groundwater of Shuangliao City, Northeast China. *Water*, 12, pp. 534. <https://doi.org/10.3390/w12020534>.

Bahri, L., 2020. Activated Charcoal. *Definitions*. <https://doi.org/10.32388/abfy2r>.

Azad, D., Pateriya, R., & Sharma, R., 2021. A Review on Preparation and Characterization of Activated Bio-Char. *International Journal of Environment and Climate Change*. <https://doi.org/10.9734/ijecc/2021/v11i430398>.

Popovici, D., Neagu, M., Dutescu-Vasile, C., Bomboş, D., Mihai, S., & Oprescu, E., 2021. Adsorption of p-nitrophenol onto activated carbon prepared from fir sawdust: isotherm studies and error analysis. *Reaction Kinetics, Mechanisms and Catalysis*, 133, pp. 483 - 500. <https://doi.org/10.1007/s11144-021-01997-8>.

Guma, B., Muwanga, A., & Owor, M., 2021. Hydrogeochemical evolution and contamination of groundwater in the Albertine Graben, Uganda. *Environmental Earth Sciences*, 80. <https://doi.org/10.1007/s12665-021-09587-6>.

Kibami, D., Hesielie, R., Zhimomi, N., Houzha, N., & Nyuwi, C., 2022. Synthesis and Characterization of a Bio Waste Material as an Effective Low-cost Adsorbent. *European Journal of Engineering and Technology Research*. <https://doi.org/10.24018/ejeng.2022.7.3.2835>.

Srivastava, A., Gupta, B., Majumder, A., Gupta, A., & Nimbhorkar, S., 2021. A comprehensive review on the synthesis, performance, modifications, and regeneration of activated carbon for the adsorptive removal of various water pollutants. *Journal of environmental chemical engineering*, 9, pp. 106177. <https://doi.org/10.1016/J.JECE.2021.106177>.

Kumar, D., Desikan, R., Subramanian, P., Karthikeyan, S., & Surendrakumar, A., 2022. PROCESS OPTIMIZATION AND SYNTHESIS OF ACTIVATED CARBON FROM COCONUT SHELL USING PHOSPHORIC ACID. *Pollution Research*. <https://doi.org/10.53550/pr.2022.v41i02.047>.

Rey-Raap, N., Granja, M., Pereira, M., & Figueiredo, J., 2020. Phosphorus-doped carbon/carbon nanotube hybrids as high-performance electrodes for supercapacitors. *Electrochimica Acta*, 354, pp. 136713. <https://doi.org/10.1016/j.electacta.2020.136713>.

Heidarinejad, Z., Dehghani, M., Heidari, M., Javedan, G., Ali, I., & Sillanpää, M., 2020. Methods for preparation and activation of activated carbon: a review. *Environmental Chemistry Letters*, 18, pp. 393-415. <https://doi.org/10.1007/s10311-019-00955-0>.

Durmuş, E., & Güneysu, F., 2020. IRON poisoning.. *The Journal of pediatrics*, 40 1, pp. 141-2 . <https://doi.org/10.28982/josam.619743>.

Khader, E., Mohammed, T., Mirghaffari, N., Salman, A., Juzsakova, T., & Abdullah, T., 2021. Removal of Organic Pollutants from Produced Water by Batch Adsorption Treatment. . <https://doi.org/10.21203/RS.3.RS-214883/V1>.

Beek, C., Hofman-Caris, C., & Zweere, G., 2020. Drinking water treatment and chemical well clogging by iron(II) oxidation and hydrous ferric oxide (HFO) precipitation. *Journal of Water Supply Research and Technology-aqua*, 69, pp. 427-437. <https://doi.org/10.2166/aqua.2020.140>.

Wang, X., Jiang, H., Zheng, G., Liang, J., & Zhou, L., 2020. Recovering iron and sulfate in the form of mineral from acid mine drainage by a bacteria-driven cyclic biomineralization system.. *Chemosphere*, 262, pp. 127567 . <https://doi.org/10.1016/j.chemosphere.2020.127567>.

Koyutürk, B., Evans, J., Multhaupt, H., Selve, S., Simke, J., Wark, M., & Fellingner, T., 2019. Sol-gel chemistry in molten Brønsted acids towards "activated" carbons and beyond.. *Nanoscale*. <https://doi.org/10.1039/c9nr01722d>.

Mukhtar, A., Mellon, N., Saqib, S., Khawar, A., Rafiq, S., Ullah, S., Al-Sehemi, A., Babar, M., Bustam, M., Khan, W., & Tahir, M., 2020. CO₂/CH₄ adsorption over functionalized multi-walled carbon nanotubes; an experimental study, isotherms

analysis, mechanism, and thermodynamics. *Microporous and Mesoporous Materials*, 294, pp. 109883. <https://doi.org/10.1016/j.micromeso.2019.109883>.

Li, X., Zhang, L., Yang, Z., Wang, P., Yan, Y., & Ran, J., 2020. Adsorption materials for volatile organic compounds (VOCs) and the key factors for VOCs adsorption process: A review. *Separation and Purification Technology*, 235, pp. 116213. <https://doi.org/10.1016/j.seppur.2019.116213>.

Scholten, L., Schmidt, C., Lecumberri-Sanchez, P., Newville, M., Lanzirotti, A., Sirbescu, M., & Steele-MacInnis, M., 2019. Solubility and speciation of iron in hydrothermal fluids. *Geochimica et Cosmochimica Acta*. <https://doi.org/10.1016/J.GCA.2019.03.001>.

Underhill, E., 2019. Nitric acid.. *The Homoeopathic recorder*, 63 10, pp. 218-20 . <https://doi.org/10.1080/00028896409342617>.

Song, Y.; Wang, K.; Zhao, F.; Du, Z.; Zhong, B.; An, G. Preparation of Powdered Activated Carbon Composite Material and Its Adsorption Performance and Mechanisms for Removing RhB. *Water* 2022, 14, 3048. <https://doi.org/10.3390/w14193048>

Aprianti, T., Sari, T., Hadiyah, F., Utama, Y., & Said, M., 2022. Powdered Activated Carbon (PAC)-Ceramic Composite Adsorbent for Iron and Aluminum Cations Removal from Acid Mine Drainage. *Journal of Engineering and Technological Sciences*. <https://doi.org/10.5614/j.eng.technol.sci.2022.54.1.13>.

Seymour, I., O'Sullivan, B., Lovera, P., Rohan, J., & O'Riordan, A., 2020. Electrochemical detection of free-chlorine in Water samples facilitated by in-situ pH

control using interdigitated microelectrodes. *Sensors and Actuators B: Chemical*.

<https://doi.org/10.26434/chemrxiv.11898126>.

Wang, J., Zhang, W., Kang, X., & Zhang, C., 2019. Rapid and efficient recovery of silver with nanoscale zerovalent iron supported on high performance activated carbon derived from straw biomass.. *Environmental pollution*, 255 Pt 1, pp. 113043 .

<https://doi.org/10.1016/J.ENVPOL.2019.113043>.

Hao, L., Liu, Y., Chen, N., Hao, X., Zhang, B., & Feng, C., 2021. Microbial removal of vanadium (V) from groundwater by sawdust used as a sole carbon source.. *The Science of the total environment*, 751, pp. 142161 .

<https://doi.org/10.1016/j.scitotenv.2020.142161>.

Mesquita, M., Deus, F., Testezlaf, R., & Diotto, A., 2019. Removal efficiency by pressurized sand filters during the filtration process. *DESALINATION AND WATER TREATMENT*. <https://doi.org/10.5004/DWT.2019.24285>.

Matsiyevska, O., Kachmar, I., & Kapitula, V., 2020. EFFICIENCY OF IRON REMOVAL FROM DRINKINGWATER WITH HOUSEHOLD FILTERS. *Theory and Building Practice*. <https://doi.org/10.23939/jtbp2020.01.081>.

Xu, J., Gao, N., Zhao, D., An, N., Li, L., & Xiao, J., 2019. Bromate reduction and reaction-enhanced perchlorate adsorption by FeCl₃-impregnated granular activated carbon.. *Water research*, 149, pp. 149-158 .

<https://doi.org/10.1016/j.watres.2018.11.005>.

Xiao, S., Cheng, M., Zhong, H., Liu, Z., Liu, Y., Yang, X., & Liang, Q., 2020. Iron-mediated activation of persulfate and peroxymonosulfate in both homogeneous and

heterogeneous ways: A review. *Chemical Engineering Journal*, 384, pp. 123265.

<https://doi.org/10.1016/j.cej.2019.123265>.